



**Parks and Recreation Board Agenda
Department of Public Services
851 South Eton-Conference Room
Tuesday, August 5, 2025
6:30 PM**

- I. Call to order**
- II. Roll Call**
- III. Announcements, Introductions of Guests & Chairpersons Comments**
 1. Thank you to all volunteers for distributing Poppleton Park Playground Improvement Flyers
- IV. Open To The Public for Items Not On the Agenda** (*two minutes per person*)
 - No one may speak a second time until everyone in the audience has spoken.
 - The chairperson may alternate speakers pro & con on issues being discussed.
- V. Approval of the minutes of: June 8, 2025** (*regular meeting*)
- VI. Unfinished Business**
 1. Bench Swing Options
- VII. New Business-** *Written and submitted by 5pm Monday at the Birmingham Ice Sports Arena, one week prior to the meeting.*
 1. Playground Design Public Input Session Poppleton Park Playground
- VIII. Miscellaneous Communications**
 1. All Communications received - Poppleton Park Playground Improvements
 2. Booth Park Natural Area-Native Perennial Plug Planting Event (Wednesday, August 6th)
- IX. Reports From Staff**
 1. Pumphouse Park and West Lincoln Well & Park Update
- X. Items for Next Meeting on Tuesday, September 9, 2025**

XI. Adjournment

Individuals requiring accommodations, such as interpreter services, for effective participation in this meeting should contact the City Clerk's Office at (248) 530-1880 (voice) or 248-644-3405 (TDD) at least one day in advance to request mobility, visual, hearing, or other assistance.

Las personas que requieren alojamiento, tales como servicios de interpretación, la participación efectiva en esta reunión deben ponerse en contacto con la Oficina del Secretario Municipal al (248) 530-1880 por lo menos el día antes de la reunión pública.
(Title VI of the Civil Rights Act of 1964).

If you cannot attend the meetings, please contact Connie Folk at the Birmingham Ice Arena (248) 530-1642.

Minutes are available for review at the Birmingham Ice Sports Arena, 2300 East Lincoln, Birmingham, MI 48009

PARKS & RECREATION BOARD MISSION STATEMENT

The Parks and Recreation Board strives to provide opportunities for the enjoyment, education, and inspiration for present and future generations of residents and visitors through stewardship of natural, cultural and recreational resources. By continuously elevating the beauty and quality of the parks and recreation system of Birmingham, the Parks and Recreation Board will promote health and wellbeing, and strengthen the community.

You may also present your written statement to:
City of Birmingham, Parks and Recreation Board
851 South Eton, Birmingham, Michigan 48009 prior to the meeting.

City of Birmingham
Parks And Recreation Board Meeting Minutes
June 10, 2025, 6:30 p.m.
851 South Eton - Conference Room

I. Call To Order

The meeting was called to order at 6:30 p.m.

II. Roll Call

Present: Vice Chair Pam Graham; Board Members Susan Collins, Jessica Einstein, Sarah Kupczyk, Anne Lipp; Alternate Board Members Narlu Castellano, Joseph Wrobel

Absent: Chair Heather Carmona; Board Member Steve Sweeney; Student Board Member Jack Bassett

Staff: Department of Public Services Director Zielinski; Ice Arena and Facilities Superintendent Folk, Parks and Recreation Manager Laird, Parks and Recreation Foreman McNab

Presenter: Lance A. Shipman, LLA, CPSI Penchura Recreation Consultant

III. Announcements, Introductions Of Guests & Chairperson Comments

- 1. Ad Hoc Senior/Recreation Center Committee (SCC) - Update**
- 2. In The Park Summer Concert Series begins: a) Friday, Jun 13, 2025**

IV. Open To The Public For Items Not On The Agenda

Jill Kahler commented regarding the Derby Well Site.

V. Approval Of The Minutes - May 6, 2025

Motion by Lipp

Seconded by Collins to approve the minutes as presented in our packet.

Motion carried, 7-0.

ROLL CALL VOTE

Yeas: Wrobel, Castellano, Kupczyk, Einstein, Collins, Graham, Lipp

Nays: None

VI. Unfinished Business

- 1. Adams Park (photos of updates)**
- 2. Booth Park Update**

The Chair introduced the item and staff presented the item. Staff answered informational questions.

Board members raised the following points during discussion:

- Some Board members would individually visit Booth Park to assess the present furniture.
- A longer table and bench might be less useful than some of the smaller options.
- The wooden bench by the trail needs to be replaced.

- It might be a long way to walk with picnic accoutrements.
- The proposed trail furniture was much more contemporary than the more traditional furniture selected for the entry to the Park.

3. Pumphouse Park & West Lincoln Well & Park Playgrounds

Staff and Mr. Shipman presented the item and answered informational questions.

Board members raised the following points during discussion:

- Presently, both Lincoln and Pumphouse Park have lower accessibility ratings.
- While it is likely more appropriate to focus wheelchair accessibility efforts at the community park level, there are likely changes that could be implemented at smaller parks to still be supportive to wheelchair accessibility.

Board comments for Pumphouse Park:

- The Board has elected not to include elevated playground components accessible by ramp.
- The playground equipment intended for ages five to 12 complies with the minimum ADA standards and the equipment intended for ages two to five exceeds the minimum ADA standards.
- A sidewalk could be added adjacent to the curb at any time.
- The house structure for the younger age range may not provide enough opportunity for highly active play. It would also be challenging for caregivers to access the house space. A climbing structure might be better. The house structure could also be complementary to another structure that encouraged more activity.
- Similar house structures have been integrated into active play by children elsewhere. The store structure also has the benefit of being partially usable by children with limited mobility.
- It might be valuable to add poured in place surfaces to the two to five area and to the swings area.
- The City should solicit donations for the benches
- The playground equipment should be expected to last about 30 years.
- Mr. Shipman did an excellent job integrating neighborhood feedback.
- Since 2020, Royal Oak and Troy have focused on improving their parks accessibility ratings to four or better when improvements are implemented.
- It was unfortunate that the plans for Pumphouse Park would not improve the accessibility rating. At the same time, the rating cannot be improved at this location until the roads are better, which is outside of the Department of Public Service's purview.
- The playground equipment is very out of date.
- It may be more feasible to improve the accessibility once the equipment is further improved and the Park has increased utilization.

Board comments for Lincoln Park:

- It might be pleasant to allow the playground to extend a bit further to the west.
- The distance from the parking lot and accessibility features may constrain where the playground should be located at Lincoln Well. It would be important to see how the access path would be drawn.
- It might be appropriate to consider retaining some of the good condition equipment in order to direct some funds towards improving wheelchair accessibility.
- It was good to hear from staff that funds were already being allocated for improving wheelchair accessibility at the parks.
- The proposal was well done. Moving the play structure for the younger age range towards the presently proposed location of the omni-swing might help establish better physical limits for the younger play area.

- It was helpful that the playground transfer points were accessibly designed. It will be necessary to prioritize access to those transfer points. Putting accessible surfaces in the middle of the equipment could maximize the amount of accessibility that can be achieved.
- There should be an accessible path of some kind connecting the parking lot to the accessible surface.
- A four-seater seesaw would promote more social interaction than a two-seater. Adding backs to that piece would be worthwhile.
- A baby swing should replace one of the other swings.
- The planned improvements to equipment, parking lot, sidewalk, and surfaces would bring this park to an accessibility rating of four.
- These plans exceed the minimum required ground level components required for an accessibility rating of five. The poured in place surface should abut some of these ground level components. Rotation or relocation of the structures may enable that access.
- Following Royal Oak to create targets for tree cover per acre would be valuable. Adding can recycling bins and bike racks would also be valuable.
- Poured in place surfaces permit water infiltration.
- The recommended conceptual changes would result in improved accessibility and sustainability in coordination with other related projects. This should be demonstrated to the Commission with support of visual aids wherever possible.
- There was some interest in trying to accommodate an adult bench swing, possibly as part of the additional amenities.
- It could be confusing to show a playground plan with two benches when there are already six benches on site.

Public Comment

Jenny O’Laughlin supported poured in place surfaces, distinguishing between ADA compliance and wheelchair accessibility, and making wheelchair accessibility the norm throughout Birmingham’s parks, and commented that her daughter would be thrilled to offer feedback about wheelchair accessibility for any of the present or proposed park conditions.

Mr. Shipman distinguished between fully inclusive and fully universal, noted that universal design limits features that can be included in playgrounds, and supported inclusivity of wheelchair users as a goal over technical adherence to universal design.

Kathleen Greiner supported the plans, adding a swinging bench for adults to Lincoln, and focusing on intensive accessibility investments at parks with larger budgets like Poppleton, and commented regarding poor Zoom audio.

Motion by Lipp

Seconded by Collins to approve the updated playground layout design for Pumphouse Park and recommend the playground equipment including installation and surfacing purchase be forwarded to the City Commission for consideration of approval.

Motion carried, 7-0.

ROLL CALL VOTE

Yeas: Wrobel, Castellano, Kupczyk, Einstein, Collins, Graham, Lipp

Nays: None

Motion by Lipp

Seconded by Collins to approve the updated playground layout design with ADA accessible surfacing and poured-in-place pathway for Lincoln Well Park and recommend the playground equipment

including installation and surfacing purchase be forwarded to the City Commission for consideration of approval, the plan to be revised in accordance with the priorities that the Board raised today, which includes replacing the double bobble rider with a four-seat see-saw and revising the configuration of the playground to create accessible internal pathways.

Public Comment

The Chair noted in response to Ms. Greiner that staff committed to adding the bench swing via other budgets, as well as playground access, reconsideration of the drop off, recycling can bins, and additional tree canopy.

Motion carried, 7-0.

ROLL CALL VOTE

Yeas: Wrobel, Castellano, Kupczyk, Einstein, Collins, Graham, Lipp

Nays: None

Motion by Lipp

Seconded by Collins to recommend Pumphouse Park remain the name of the park, and that the name of West Lincoln Well Park be changed to West Lincoln Park.

Motion carried, 7-0.

ROLL CALL VOTE

Yeas: Wrobel, Castellano, Kupczyk, Einstein, Collins, Graham, Lipp

Nays: None

VII. New Business

VIII. Miscellaneous Communications

- 1. Communication regarding parks**
- 2. Communication regrading Kenning Park**
- 3. Communication regarding Pumphouse Park**
- 4. Communications regarding Accessibility**
- 5. Communication regarding Golf Courses**

Board comments regarding the golf course correspondence:

- The Board appreciated the correspondence. There were some concerns to validate and some in need of correction.
- It was not factual that Springdale was not in operation last season.
- It was hard to let the concerned letterwriter know about the City's efforts with the golf courses since the letter was anonymous.

IX. Reports From Staff

X. Items For Next Meeting

- 1. July Parks and Recreation Month**

PRF McNab presented the item.

Board comments were as follows:

- Staff's proposal of a park scavenger hunt could be fun.
- Other activities to encourage residents to visit parks they do not usually visit could also generate interest.

XI. Adjournment

The meeting was adjourned at 9:11 p.m.



Connie Folk, Ice Arena and Facilities Superintendent

Laura Eichenhorn, City Transcriptionist



MEMORANDUM

Department of Public Services

DATE: July 31, 2025

TO: Parks and Recreation Board

FROM: Carrie Laird, Parks and Recreation Manager

SUBJECT: Bench Swing Options

At the May 6, 2025 Parks and Recreation Board meeting, during the public input session for the West Lincoln Well Park playground, members of the community expressed interest in the installation of a bench swing at the park, and this idea was supported by the Board if funding allows. The Department of Public Services (DPS) has budgeted for park system wide site furnishings for items such as benches, drinking fountains, bike racks and the like, therefore funding is available to accomplish the purchase of a swing bench for West Lincoln Well Park and potentially other parks as we move along with improvements.

DPS staff has researched different styles of bench swings from various vendors and are looking for feedback from the Parks and Recreation Board. Enclosed with this report are various styles and information about each including warranty, in order of lowest price to highest.

- Premier Polysteel
- Noblewins
- Custom Bench Swing (Booth Park)
- Landscape Forms

Premier Polysteel





PREMIER POLYSTEEL
The Best Commercial Outdoor Furniture Available. Period.

Premier Polysteel
A Division of ADA Enterprises, Inc.
305 Enterprise Drive
PO Box 77
Northwood, IA 50459
Ph: 641-324-2750 Fax: 641-324-1092
Toll Free US & Canada: 877-746-3826

Quote	
Quote Number: 31737	Quoted Date: 07/29/2025

Quote To	
Connie Folk	
City of Birmingham	
Connie Folk	
851 S. Eton St.	
Birmingham , MI 48009	
United States	
Ph: 248-530-1642	

Expiration Date: 08/12/2025
Terms: Due With Order
Ship Via: WorldWideExp
Salesperson Matthew Erickson
Reference: Ship to 48009

Line	Quantity	Part Number/Description	Unit Price	Ext Price
001	1 ea	971-SM12-033 6' GC Laser DB Mem Swing-3 6' Grand Contour Laser Direct Bury Memorial Swing-Hunter Green	\$1,613.70	\$1,613.70

Line	Quantity	Part Number/Description	Unit Price	Ext Price
002	1 ea	FREIGHT Ship to 48009	\$699.00	\$699.00

Lead Time: 4 Weeks **Total: \$2,312.70**

Payment Terms: As stated above

Freight: Please note this freight quote does not include a lift gate or special services. Should you need special services, let us know and we can adjust the quote as needed.

Warranty: All products manufactured by Premier Polysteel come with a 20 year limited warranty!

Cancellation Policy: Orders may be cancelled within 72 hours without penalty. Cancellation of order after 72 hours may be subject to restocking fees per our company terms.

All prices are net U.S. dollars. All local, state or other taxes, (if applicable) are the responsibility of the purchaser.

Freight note: If you need a lift gate and have not requested one, please notify us ASAP. Your freight costs and services will need to be adjusted accordingly.



6' Grand Contour Expanded Metal Direct Bury Swing

974-S12

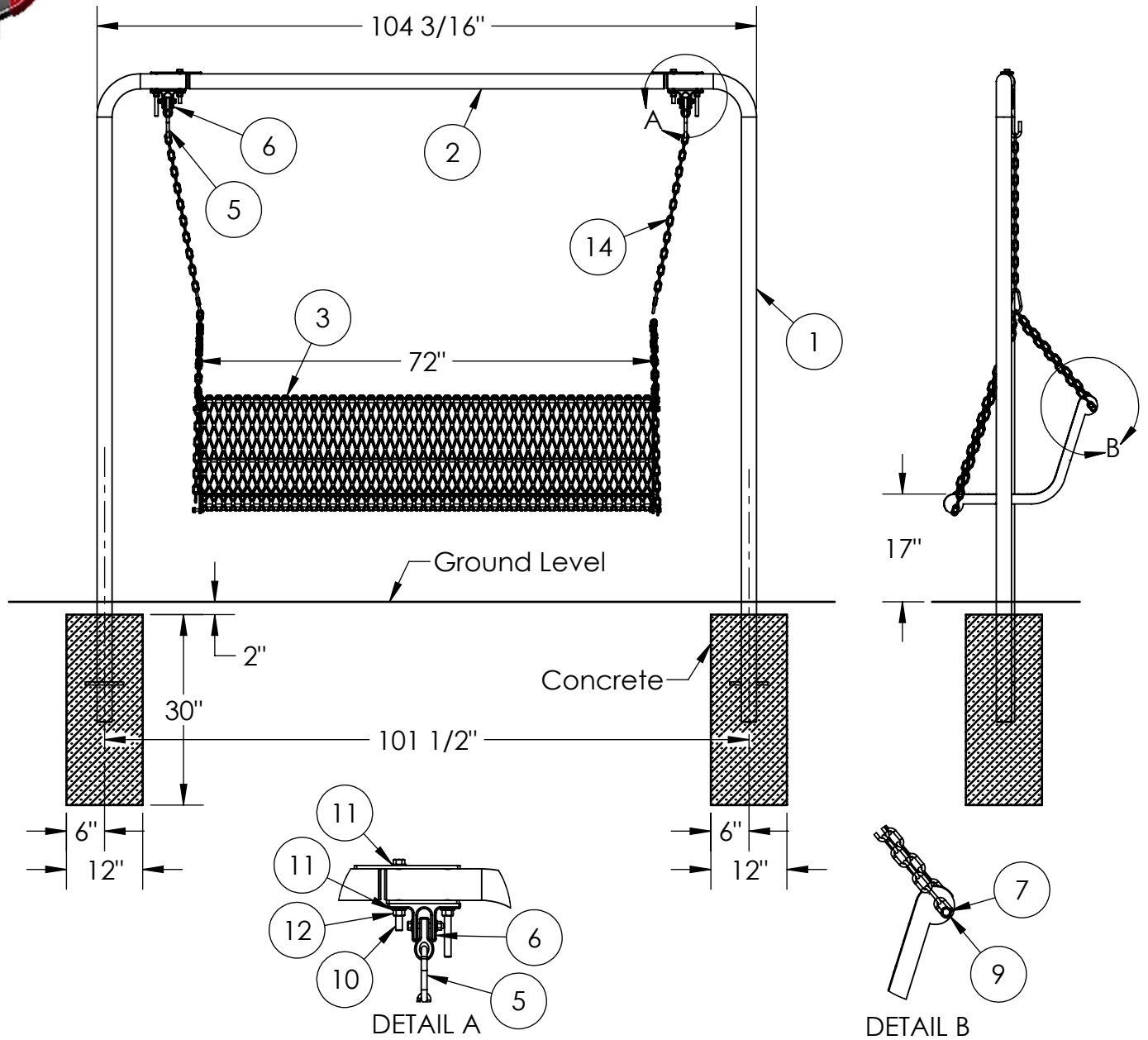

ITEM NO.	PART NUMBER	DESCRIPTION	QTY.
1	635-002	Contour Swing Direct Bury Post	2
2	635-032	6' Contour Swing Brace	1
3	623-S15	6' GC Expanded Swing	1
4	635-100	1/4" Grade 30 Proof Chain	2
5	S-Hook	Swing Hook	2
6	SHT05	Swing WB Hanger	2
7	516-058	3/8"x1-1/2" SS Hex Bolt	4
8	517-028	3/8" Zinc Nylock Nut	4
9	516-023	3/8" SS Flat Washer	8
10	516-065	1/2"x5" SS Hex Bolt	4
11	516-027	1/2" SS Flat Washer	8
12	516-036	1/2" SS NyLock Nut	4



PREMIER POLYSTEEL

The Best Commercial Outdoor Furniture Available. Period.



SIZE
A



Tools List

- 7/16" Drill bit
- 9/16" Drill bit
- 9/16" Socket
- 9/16" Wrench
- Level
- Impact Gun (Optional)
- Drill

This product uses Hardware Pack HWPK14
(you may receive extra hardware)

- 4 qty. 3/8" x 1-1/2" SS Hex Bolt
- 4 qty. 3/8" SS Nylock Nut
- 8 qty. 3/8" SS Flat Washer
- 4 qty. 1/2" x 5" SS Hex Bolt
- 4 qty. 1/2" SS Nylock Nut
- 8 qty. 1/2" SS Washer
- 2 qty. S-Hook

1. Bore two 12" diameter holes into the ground as per drawing.
2. The holes should be at least 32" deep as shown or below the frost line in your area, which ever is greater.
3. Place 4-6" of pea rock in hole.
4. Drill out plastic from all mounting holes on the swing seat with a 7/16" drill bit.
5. Drill out plastic from all mounting holes on the posts and brace with a 9/16" drill bit.
6. Bolt items 1, 2 and 6 together using the 1/2" fixings provided.
7. Place the posts into the holes and support them.
8. Attach the swing hooks onto the swing WB hangers.
9. Attach the chains to the swing hooks.
10. Bolt the swing seat to the chains using 3/8" fixings provided.
11. Level swing seat and adjust posts to desired height. Recommended height is 17" from the ground to the top front of the seat.
12. Fill the holes with concrete to approximately 2" below ground level or fill to no higher than ground level and crown the top so that water will run off.
13. Let stand for 24 hours before removing the supports.

Periodic check of bolts tightness recommended



PREMIER POLYSTEEL

The Best Commercial Outdoor Furniture Available. Period.





6' Grand Contour Expanded Metal Direct Bury Swing

974-S12



PREMIER POLYSTEEL

The Best Commercial Outdoor Furniture Available. Period.



SIZE
A



6' Grand Contour Expanded Metal Direct Bury Swing

974-S12

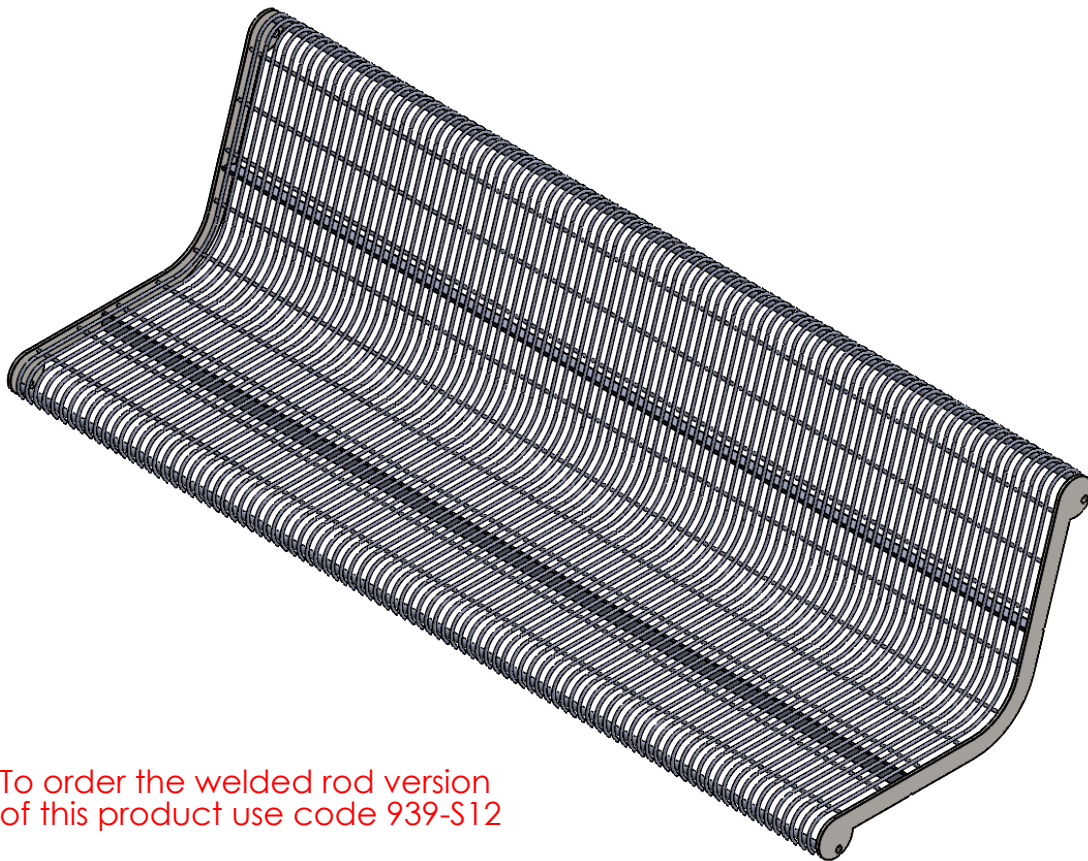
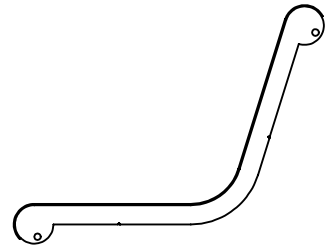
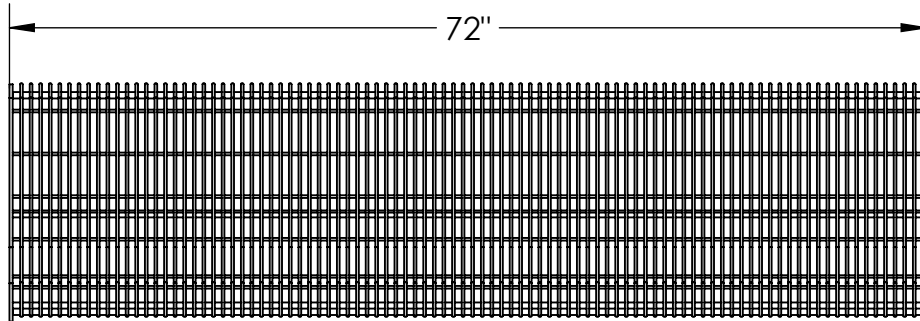

To order the welded rod version of this product use code 939-S12

ITEM NO.	PART NUMBER	DESCRIPTION	QTY.
1	623-S05	6' GC Welded Rod Swing	1



PREMIER POLYSTEEL

The Best Commercial Outdoor Furniture Available. Period.



SIZE
A



6' Grand Contour Expanded Metal Direct Bury Swing

974-S12

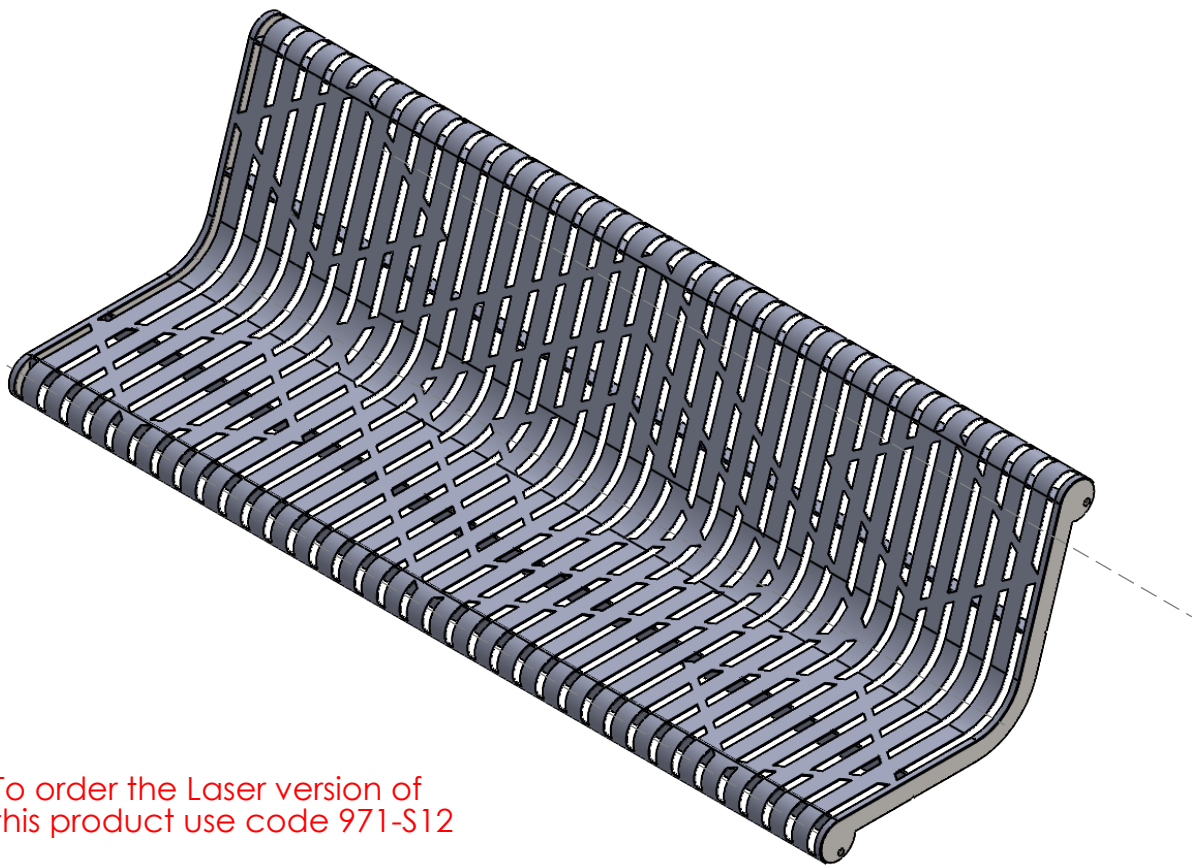
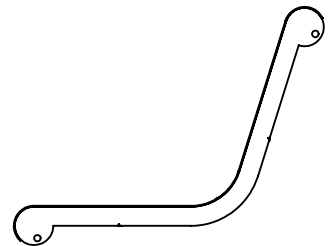
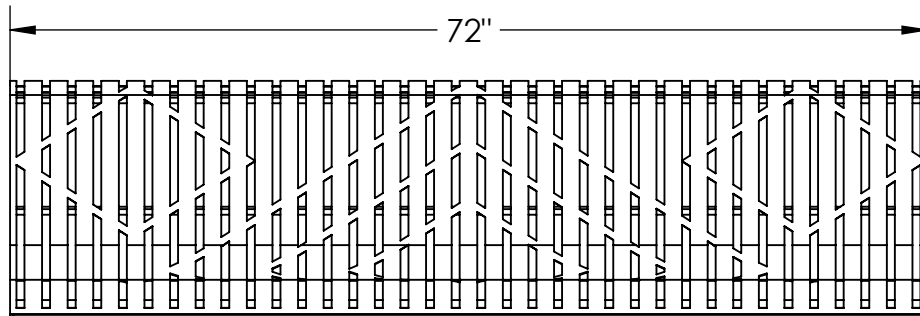

To order the Laser version of this product use code 971-S12

ITEM NO.	PART NUMBER	DESCRIPTION	QTY.
1	625-S05	6' GC Laser Swing	1



PREMIER POLYSTEEL

The Best Commercial Outdoor Furniture Available. Period.



SIZE
A



PREMIER POLYSTEEL

The Best Commercial Outdoor Furniture Available. Period.

THE PREMIER POLYSTEEL 20-YEAR LIMITED WARRANTY

Premier Polysteel, because of its very high-quality standards and superior design and materials, is pleased to provide a twenty-year limited warranty on all of its standard products from date of purchase by the original user. Although our limited warranty applies to normal wear and our plastics are very fade resistant, we cannot warrant against natural fading due to sunlight. This warranty is based upon the product being used as per its originally designed purpose and specifically excludes any failure that is caused by misuse, neglect, accident, or improper maintenance. Premier Polysteel will repair or replace, on a pro-rated basis, all parts that fail to perform under the circumstances outlined above. All freight and installation charges are to be paid by user.



Office: 641-324-2750 • Toll Free: 877-746-3826 (US & CAN)

Email: sales@premierpolysteel.com

Web: www.premierpolysteel.com



Noblewins



Birmingham, MI
151 Martin Street
Birmingham, MI 48009
United States

Carrie Laird
claird@bhamgov.org
248.530.1800

Reference: 20250722-112932762
Quote created: July 22, 2025
Quote expires: August 21, 2025
Quote created by: Liz Hill
Account Executive
ehill@noblewins.com

Comments from Liz

Final freight cost will be calculated at the time of order.

Products & Services

Image	Item & Description	Quantity	Unit Price	Total
	Everglade - Primed Bench comes primed and prepared for community artists to create their own custom mural design on-site.	1	\$8,475.00	\$8,475.00

One-time subtotal \$8,475.00

Estimated Freight \$850.00

Total \$9,325.00

[Terms & Conditions](#)

Signature

Before you sign this quote, an email must be sent to you to verify your identity. Find your profile below to request a verification email.

Carrie Laird

claird@bhamgov.org

[sig|req|signer1]

Questions? Contact me



Liz Hill

Account Executive

ehill@noblewins.com

Noblewins

15000 Madison Avenue

Floor 2

Lakewood OH 44107

United States



NOBLEWINS
2025 CATALOG





NOBLEWINS

THANK YOU FOR EXPLORING NOBLEWINS.

YOUR TIME AND INTEREST MEAN A LOT TO US. AT NOBLEWINS, WE CRAFT OUTDOOR FURNITURE THAT'S BUILT TO LAST AND DESIGNED TO INSPIRE – BLENDING DURABILITY, ART, AND SUSTAINABILITY INTO EVERY PIECE.

WE BELIEVE OUTDOOR SPACES SHOULD BE AS TIMELESS AS THE MATERIALS WE USE. WHETHER YOU'RE ENVISIONING A BOLD GATHERING SPOT OR ADDING PUBLIC ART TO YOUR COMMUNITY, WE'RE EXCITED TO BE PART OF YOUR JOURNEY.

LET'S CREATE SOMETHING LASTING TOGETHER.





NOBLEWINS

PRIMARY MATERIAL



RETIRED WIND TURBINE BLADE

MATERIAL BENEFITS

- INCREDIBLY DURABLE
- NO MAINTENANCE
- NO RUST OR CORROSION
- MOISTURE RESISTANT
- EXTREME WEATHER? NO PROBLEM
- VISIBLE WAY TO "GO GREEN"



SECONDARY MATERIALS

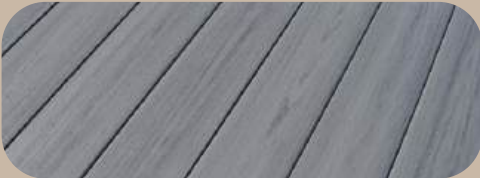

UPCYCLED PVC

A SUSTAINABLE, LOW-MAINTENANCE FINISH THAT MIMICS NATURAL WOOD. WILL NOT SPLINTER, WARP OR FADE.



ALUMINUM FRAMES

LIGHTWEIGHT, RUST-RESISTANT, AND BUILT TO PROVIDE LASTING STRUCTURAL SUPPORT IN ANY ENVIRONMENT



STAINLESS STEEL FASTENERS

CORROSION-RESISTANT AND BUILT TO WITHSTAND THE HARSHTEST OUTDOOR CONDITIONS FOR LASTING STRENGTH AND STABILITY



NOBLEWINS

FINISHES

WE COMPLETE EACH PIECE WITH AN ANTI-GRAFFITI FINISH, USING A TWO-PART EPOXY PAINT DESIGNED TO WITHSTAND HARSH ENVIRONMENTS.



PRIMED

A BLANK CANVAS THAT JUMPSTARTS PUBLIC ART, INVITES COMMUNITY CREATIVITY, AND BRINGS LOCAL STORIES TO LIFE

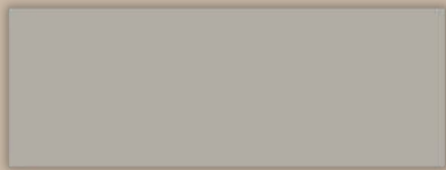

STONE
LIGHT BEIGE, SUBTLE
AND INVITING

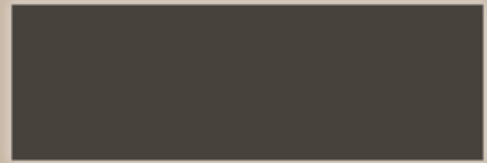

TIMBER
RICH BROWN, WARM
AND TIMELESS

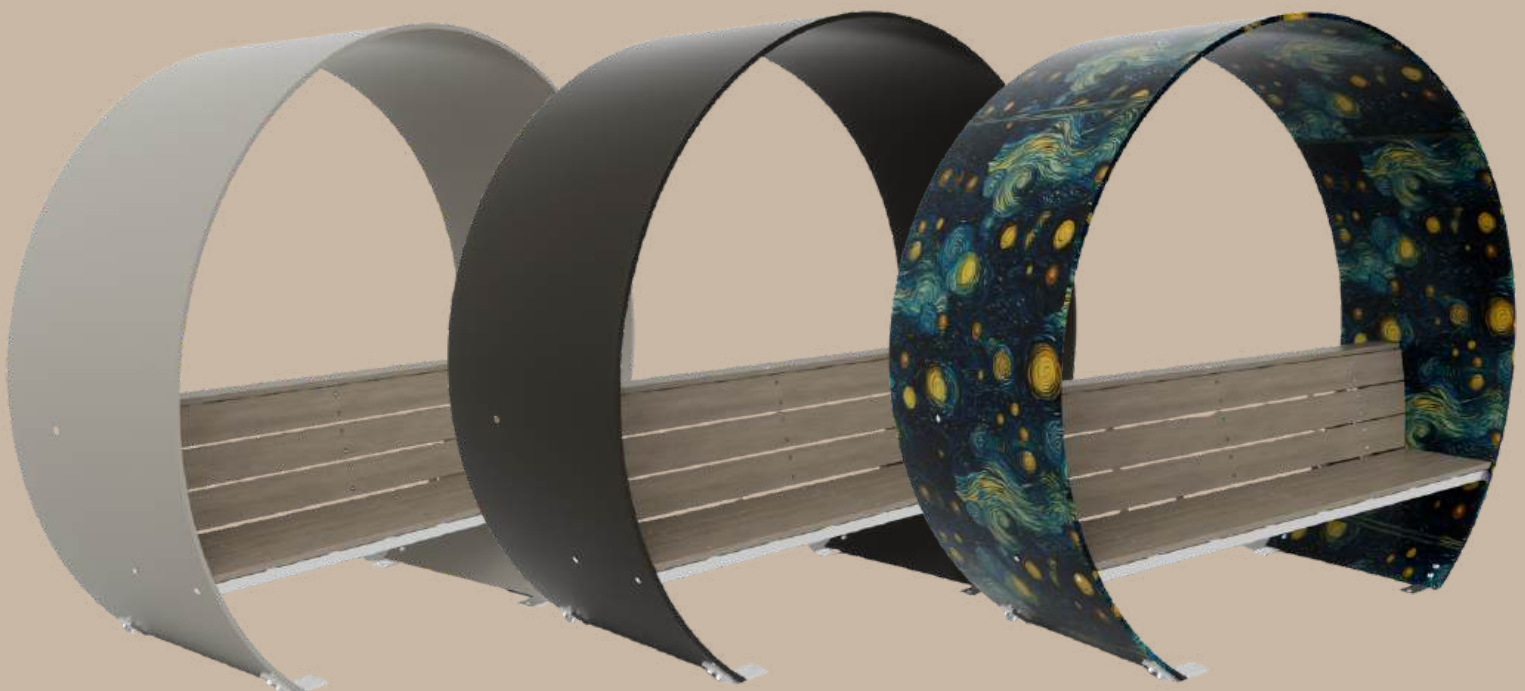



NOBLEWINS

PRIMED PROJECTS

EMPOWER YOUR COMMUNITY. TURN YOUR SPACES INTO STATEMENTS.





YOSEMITE
\$3,775

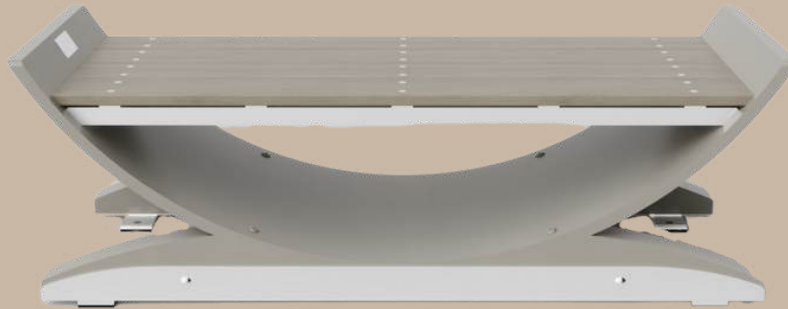

WIDTH: 60-72"
DEPTH: 24"
HEIGHT: 21"
SEAT HEIGHT: 18"
WEIGHT: 400 LBS

BIG BEND
\$3,975



WIDTH: 72-84"
DEPTH: 24"
HEIGHT: 40"
SEAT HEIGHT: 18"
WEIGHT: 400 LBS

ZIÖN
\$8,475

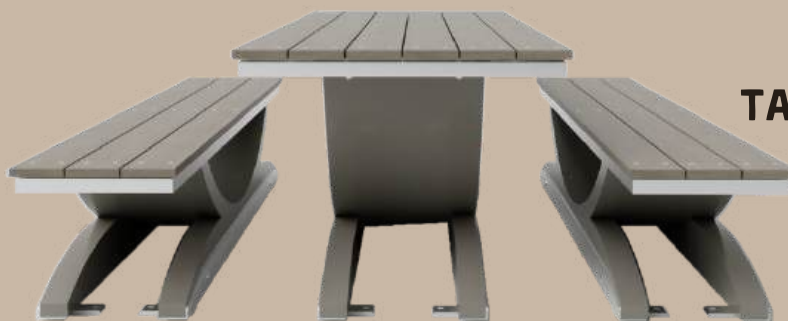

WIDTH: 8'
TABLE DEPTH: 40"
TABLE HEIGHT: 32.5"
SEAT DEPTH: 17"
SEAT HEIGHT: 18"
WEIGHT: 850 LBS

SEQUOIA
\$4,975



WIDTH: 72-84"
DEPTH: 30"
HEIGHT: 40"
SEAT HEIGHT: 18"
WEIGHT: 1200 LBS



YOSEMITE

\$3,775

WIDTH: 60-72"

DEPTH: 24"

HEIGHT: 21"

SEAT HEIGHT: 18"

WEIGHT: 400 LBS

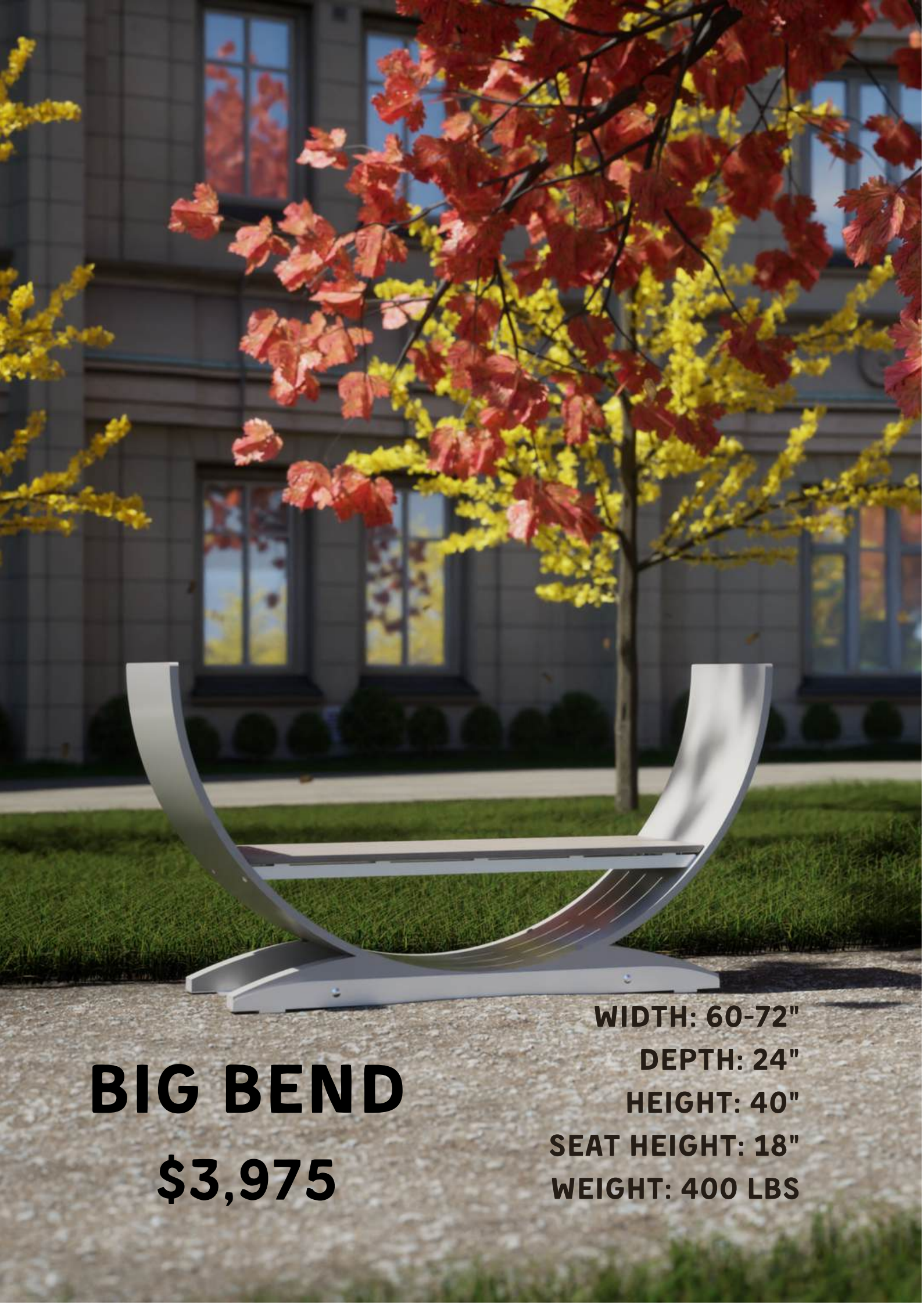

BIG BEND

\$3,975

WIDTH: 60-72"

DEPTH: 24"

HEIGHT: 40"

SEAT HEIGHT: 18"

WEIGHT: 400 LBS

ZIÖN

\$8,475



WIDTH: 8'

TABLE DEPTH: 40"

TABLE HEIGHT: 32.5"

SEAT DEPTH: 17"

SEAT HEIGHT: 18"

WEIGHT: 850 LB

SEQUOIA

\$4,975

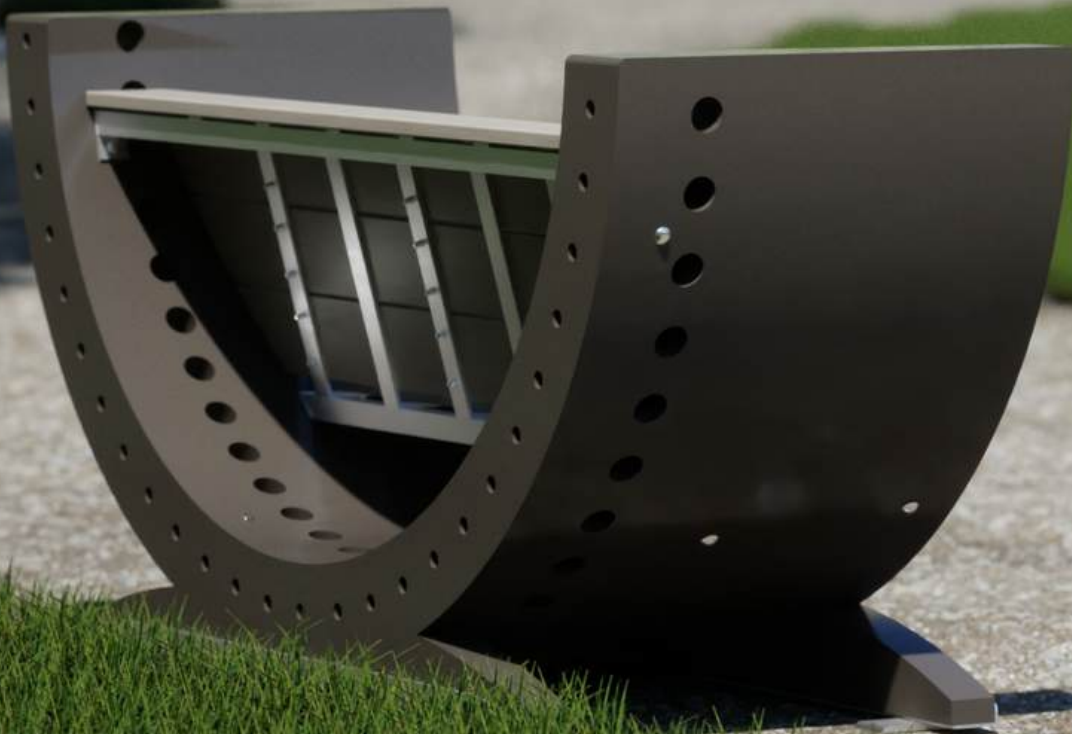

WIDTH: 72-84"

DEPTH: 30"

HEIGHT: 40"

SEAT HEIGHT: 18"

WEIGHT: 1200 LBS



NOBLEWINS

ARCH

\$8,475

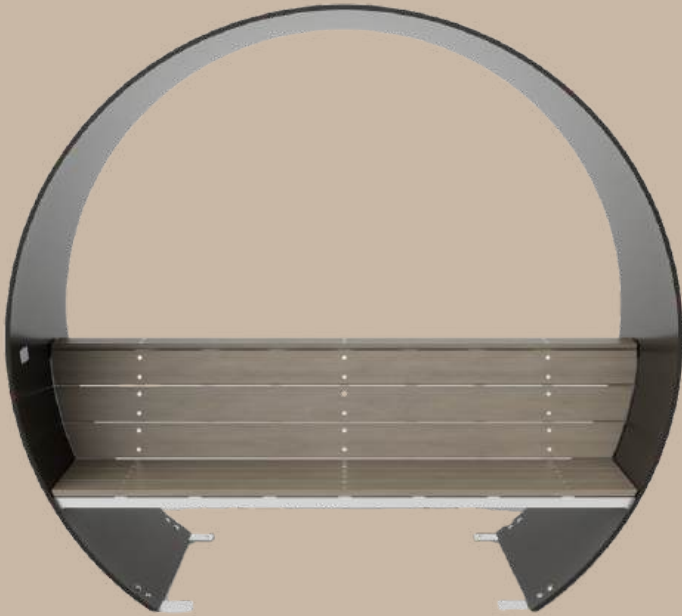

SEAT HEIGHT: 18"
SEAT WIDTH: 77"
WEIGHT: 2000 LBS
WIDTH: 90-96"
DEPTH: 36"
HEIGHT: 80-86"

EVERGLADE

\$8,475



SEAT HEIGHT: 18"
SEAT WIDTH: 48"
WEIGHT: 2000 LBS
WIDTH: 90-96"
DEPTH: 36"
HEIGHT: 80-86"

ACADIA

\$6,495

LIMITED SUPPLY
PRIMED ONLY



WIDTH: 50-70"
DEPTH: 30"
HEIGHT: 91-112"
SEAT HEIGHT: 18"
WEIGHT: 550-650 LBS



ARCH

\$8,475

WIDTH: 90-96"

DEPTH: 36"

HEIGHT: 80-86"

SEAT HEIGHT: 18"

SEAT WIDTH: 77"

WEIGHT: 2000 LBS

EVERGLADE

\$8,475



WIDTH: 90-96"

DEPTH: 36"

HEIGHT: 80-86"

SEAT HEIGHT: 18"

SEAT WIDTH: 48"

WEIGHT: 2000 LBS

ACADIA

\$6,495



WIDTH: 50-70"

DEPTH: 30"

HEIGHT: 91-112"

SEAT HEIGHT: 18"

WEIGHT: 550-650 LBS

**LIMITED SUPPLY
PRIMED FINISH ONLY**



COST COMPARISON

What Will Your Bench Cost Over 25 Years?

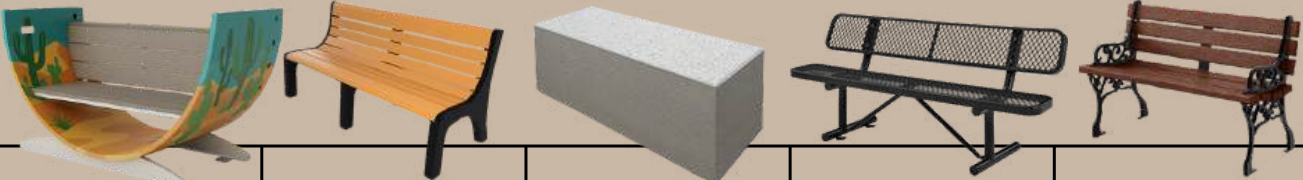

Feature	NOBLEWINS	Composite Wood	Concrete	Metal	Traditional Wood
Average Cost	\$6,000	\$3,000	\$5,000	\$3,500	\$2,000
Maintenance Cost	\$0	\$250/year	\$240/year	\$320/year	\$520/year
Replacement Cycle	None	2x	2x	2-3x	3x
Total 25-Year Cost	\$6,000	\$9,250	\$11,000	\$11,500	\$15,000

WHY CHOOSE NOBLEWINS

- Lowest Total Cost – No maintenance or replacements needed over 25 years
- No Assembly Required – Delivered fully built and ready to install
- Durability That Lasts – Built to withstand the elements and heavy use
- Outperforms Traditional Options – Replaces 2-3 wood, metal, or concrete benches
- Public Art Ready – Custom-painted options turn seating into lasting community art
- Sustainable Choice – Made from upcycled wind turbine blades



NOBLEWINS

PURCHASING INFO

- **SOLE SOURCE SUPPLIER**
- **MADE TO ORDER**
- **LIMITED PRODUCTION SLOTS**
- **LEAD TIME: 3-6 MONTHS**
- **ORDER PROCESS**
 - **APPROVE QUOTE**
 - **INVOICE ISSUED**
 - **PRODUCTION BEGINS UPON PAYMENT**



**CRAFTED WITH PURPOSE.
BUILT TO LAST.
DESIGNED TO INSPIRE.**



NOBLEWINS

READY TO BRING YOUR VISION TO LIFE?

(440) 306-9006

INFO@NOBLEWINS.COM



NOBLEWINS

To Whom It May Concern:

This letter is to confirm that the products made from retired wind turbine blades supplied by Noblewins LLC are sole source products, sold and distributed exclusively by Noblewins LLC. No other company supplies a similar or competing product. These products must be purchased directly by a customer from Noblewins LLC or donated to them. There are no agents or dealers authorized to represent these products.

Competition is precluded by the exclusive nature of these products and the proprietary technology involved in their creation. There are no other like products available for purchase that would serve the same function due to this exclusivity.

Our products come with a 25-year warranty, demonstrating our commitment to quality and long-term value for our customers.

If you desire additional information, don't hesitate to contact us at 440-306-9006 at any time or visit our website at www.noblewins.com.

Thank you for your interest in our products and your desire to reimagine your spaces and inspire your citizens, students, and visitors with sustainable solutions.

Sincerely,

Brian Donahue

President

Noblewins LLC

donahue@noblewins.com

Custom (Booth Park)

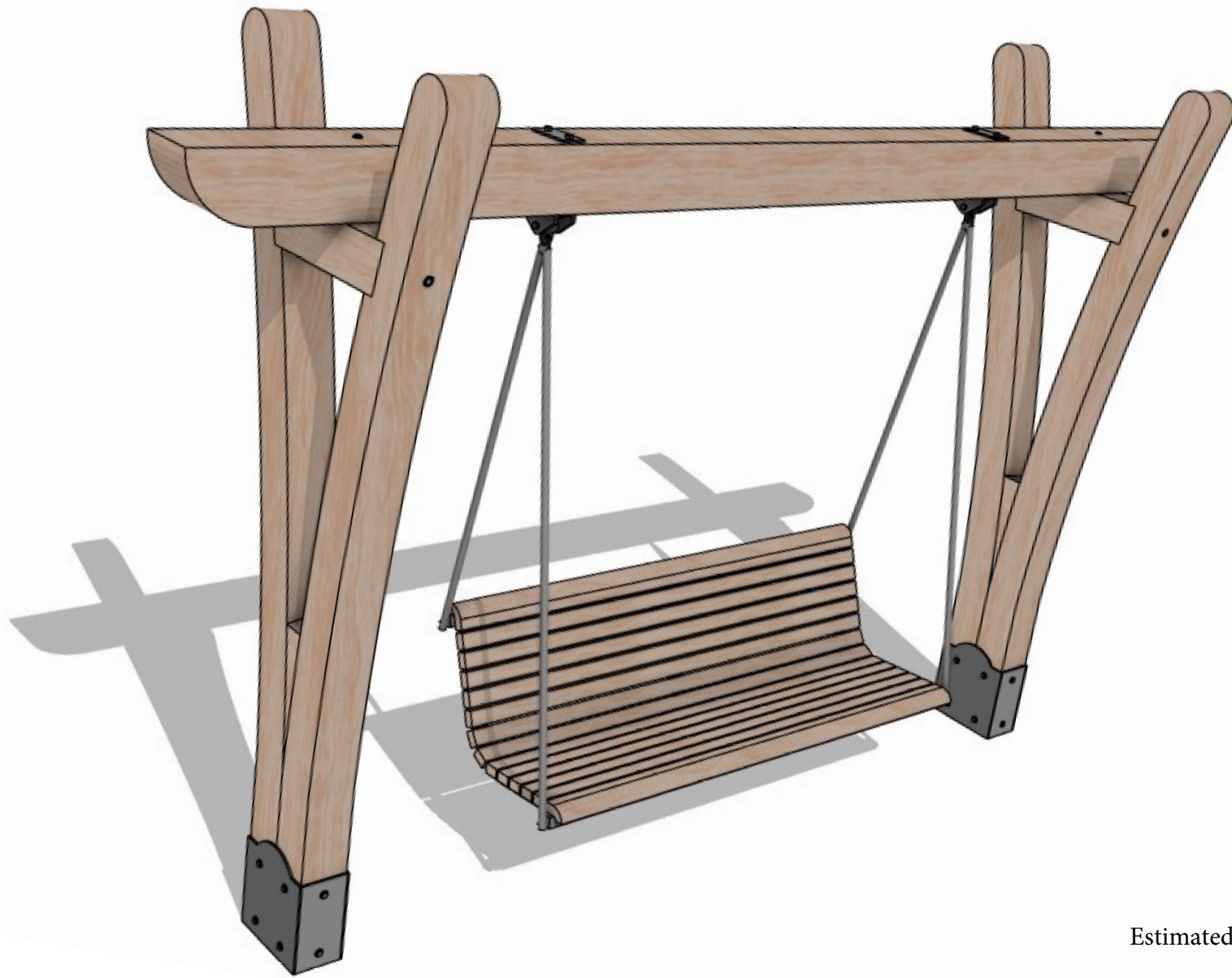

Estimated Cost: \$15,800-17,500

Landscape Forms

Fwd: Swinging Bench Pictures/Prices

Connie Folk <cfolk@bhamgov.org>
To: "Laird, Carrie" <Claird@bhamgov.org>

Wed, Jun 11, 2025 at 2:32 PM

----- Forwarded message -----

From: **Scott Black** <sblack@landscapeforms.com>
Date: Wednesday, June 11, 2025
Subject: Swinging Bench Pictures/Prices
To: Connie Folk <Cfolk@bhamgov.org>

Hi Connie,

Thanks for reaching out. Attached is our S431 swing option package as well as a couple built swings and a little movie of the swing.

Our team can provide custom ready (pre-engineered) swings, supports, and frame and there are a couple options of the swing type. Most of these types of swings come ready for installation and basically (6) complete pieces. There are (26) powdercoat colors standard to choose from and provide a service for a review and stamp from a licensed Structural Engineer. Our team will also assist the contractor with recommendations for the footing design for the swing posts.

Here is a budget breakdown for the Parc Vue Swing, suspension kit, supports and posts:



- Two post U-frame structure = \$9,351
- Parc Vue swings (including all connections and clamps) = \$9,960
- (1) Structural stamp (excluding footings) = \$3,500

Total = \$22,811 (excluding tax and freight)

Once you have had an opportunity to review everything, please let me know what questions you have. Thanks and have a great week!

landscapeforms

Scott Black | MBA, PLA, ASLA
Business Development
Southeast and Northern Michigan
Landscape Forms, Inc.
Office: 269-276-4520
Mobile: 248-504-8120
sblack@landscapeforms.com
www.landscapeforms.com

From: Connie Folk <Cfolk@bhamgov.org>
Sent: Wednesday, June 11, 2025 12:00 PM
To: Scott Black <sblack@landscapeforms.com>
Subject: Swinging Bench Pictures/Prices

Good Afternoon-

May I have information on a swinging bench with pictures/videos and prices.

Thank You

--

Connie J. Folk
City of Birmingham
Ice Arena and Facilities Superintendent
[2300 East Lincoln](http://2300EastLincoln.com)
Birmingham, MI 48009
Cfolk@bhamgov.org
248.530.1642 (T)

--

Connie J. Folk
City of Birmingham
Ice Arena and Facilities Superintendent
[2300 East Lincoln](http://2300EastLincoln.com)
Birmingham, MI 48009
Cfolk@bhamgov.org
248.530.1642 (T)

8 attachments



Landscape Forms_Austin Swing - Buchanan Sq - Coquitlam.jpg
234K



Landscape Forms_BNA Airport Austin Swing.jpg
655K



Landscape Forms_Parc Vue swing.jpg
785K



Landscape Forms_Parc Vue Swing2.JPG
1163K



Landscape Forms_Swings-1.jpg
1470K



Landscape Forms_Swings-2.JPG
3017K

 **Landscape Forms_Studio 431 Custom-Ready Swings.pdf**
3939K

 **IMG_5964.MOV**
4286K





landscapeforms

Studio 431

Two Post Cantilever Structure with Perforated Metal Roof

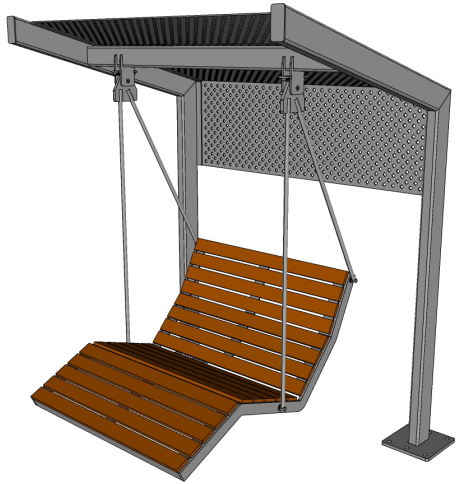

S431 Lounge Swing

Ipe, Powder Coated Steel
Stainless Steel Hardware
Perforation Pattern by Others



S431 Bench Swing

Ipe, Powder Coated Steel
Stainless Steel Hardware
Perforation Pattern by Others



Parc Vue Swing

Powder Coated Steel
Stainless Steel Hardware
Perforation Pattern by Others

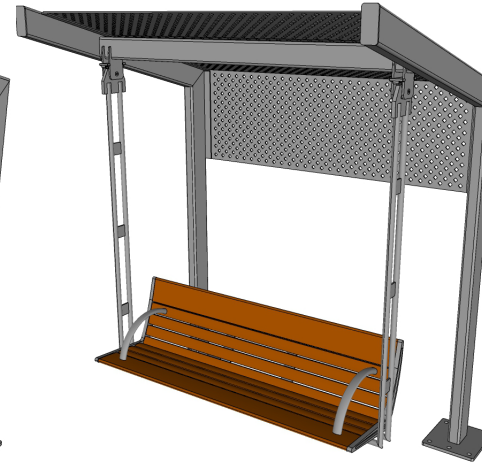

Austin Swing - Wood

Ipe, Powder Coated Aluminum
Stainless Steel Hardware
Perforation Pattern by Others



Austin Swing - Metal

Powder Coated Aluminum
Stainless Steel Hardware
Perforation Pattern by Others

Two Post Cantilever Structure with Wood Slat Roof

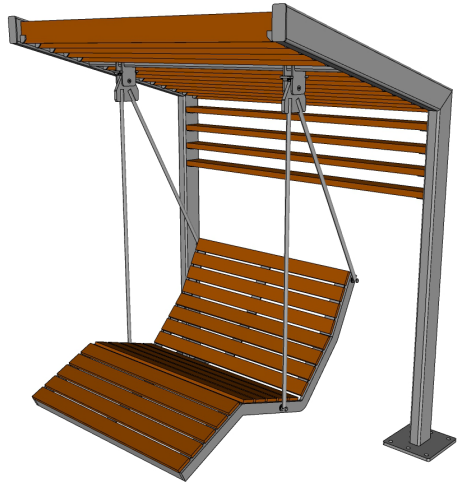

S431 Lounge Swing

Ipe, Powder Coated Steel
Stainless Steel Hardware
Ipe Roof Slats



S431 Bench Swing

Ipe, Powder Coated Steel
Stainless Steel Hardware
Ipe Roof Slats

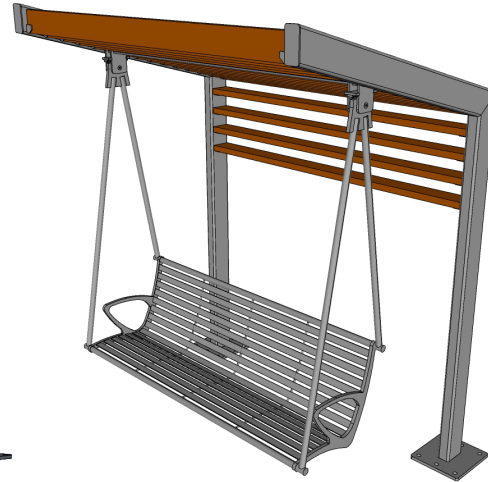

Parc Vue Swing

Powder Coated Steel
Stainless Steel Hardware
Ipe Roof Slats

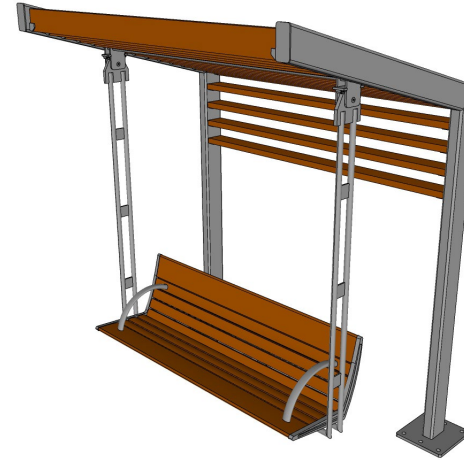

Austin Swing - Wood

Ipe, Powder Coated Aluminum
Stainless Steel Hardware
Ipe Roof Slats

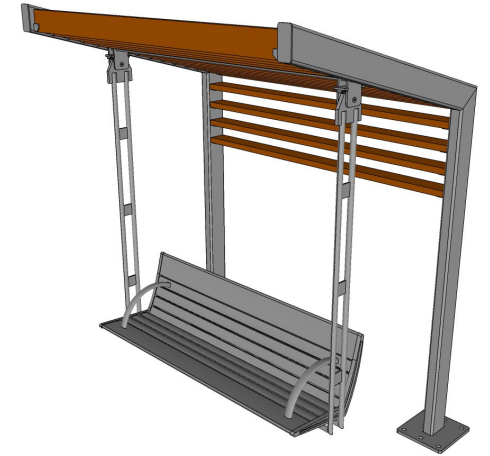

Austin Swing - Metal

Powder Coated Aluminum
Stainless Steel Hardware
Ipe Roof Slats

Two Post U-Frame Structure

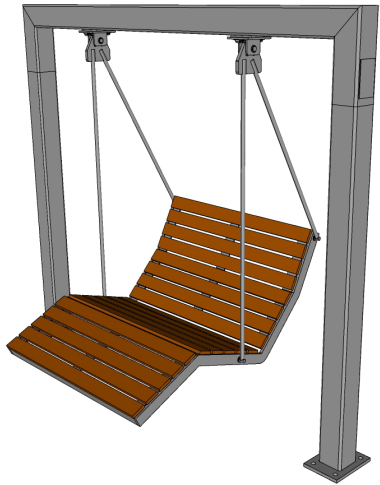

S431 Lounge Swing

Ipe, Powder Coated Steel
Stainless Steel Hardware



S431 Bench Swing

Ipe, Powder Coated Steel
Stainless Steel Hardware

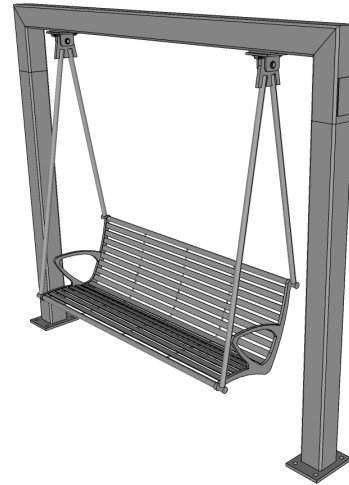

Parc Vue Swing

Powder Coated Steel
Stainless Steel Hardware

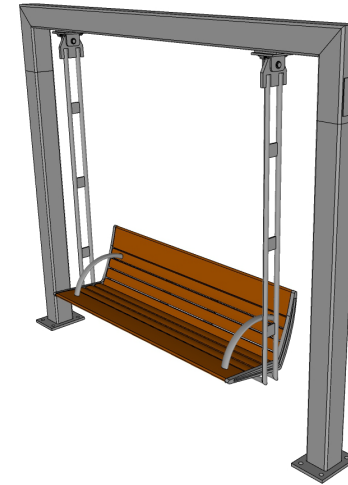

Austin Swing - Wood

Ipe, Powder Coated Aluminum
Stainless Steel Hardware

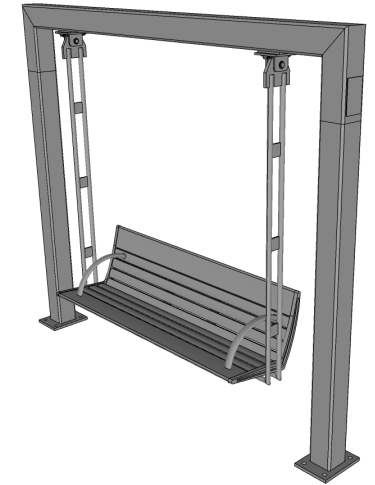

Austin Swing - Metal

Powder Coated Aluminum
Stainless Steel Hardware



LEASING
INQUIRIES
877-465-5212
WWW.CENTURYLINK.COM



BNA

PAY
HERE P5



Fwd: Swinging Bench Pictures/Prices

Connie Folk <Cfolk@bhamgov.org>

Wed, Jul 30, 2025 at 1:06 PM

To: "Laird, Carrie" <Claird@bhamgov.org>, Brad McNab <bmcnab@bhamgov.org>

----- Forwarded message -----

From: **Scott Black** <sblack@landscapeforms.com>

Date: Wed, Jul 30, 2025 at 12:58 PM

Subject: Re: Swinging Bench Pictures/Prices

To: Connie Folk <Cfolk@bhamgov.org>

Hi Connie,

Here is that standard warranty from Landscape Forms that would include the swings we discussed:

Standard Landscape Forms Site Furnishings

Your complete satisfaction and future business are our goals. Standing behind our products has been a cornerstone of our commitment to quality and service since our founding in 1969. Our products will satisfactorily perform their intended function, under normal conditions, for many years. For our Cochran and Morrison product, we define normal conditions as presence within protected public spaces, such as on corporate campuses or in community courtyards. If you are ever dissatisfied with one of our products, please contact us and let us demonstrate our commitment.

Landscape Forms, Inc. warrants all products (other than noted exceptions) to be free from defects in material and/or workmanship for a period of three (3) years from date of invoice. Note exceptions:

- *This warranty does not cover color change in the HDPE material, including fading due to weathering and sun exposure, for the Harvest, Americana and Glide products. Color matches on replacement parts for these products are not guaranteed or warranted. Furniture that has been exposed to sun and weathering may have color and appearance changes.*
- *Bravo Bistro is warrantied for a period of 1 year.*
- *The Monterey line's Tradewind fabric has a 5-year warranty for performance, and a 3-year warranty for color loss.*
- *Products provided by our partners Urbidermis Santa & Cole, Escofet, TUUCI, Legrand, and Renson (Scenic) are covered by their individual warranties.*
- *This warranty does not apply to damage resulting from accident, alteration, misuse, tampering, negligence, or abuse.*

Landscape Forms, Inc. will, at its option, repair, replace, or refund the purchase price of any items found defective upon inspection by an authorized Landscape Forms, Inc. service representative.

Please let me know if you have any questions or need anything additional.
Thanks and have a great week!

landscapeforms

Scott Black | MBA, PLA, ASLA
Business Development
Southeast and Northern Michigan
Landscape Forms, Inc.
Office: 269-276-4520
Mobile: 248-504-8120
sblack@landscapeforms.com
www.landscapeforms.com

DESIGN. CULTURE. CRAFT.

From: Connie Folk <Cfolk@bhamgov.org>
Sent: Wednesday, July 30, 2025 8:25 AM
To: Scott Black <sblack@landscapeforms.com>
Subject: Re: Swinging Bench Pictures/Prices

Good Morning-

What would be the warranty on this bench

[Quoted text hidden]

[Quoted text hidden]



MEMORANDUM

Department of Public Services

DATE: July 30, 2025

TO: Parks and Recreation Board

FROM: Carrie Laird, Parks and Recreation Manager

SUBJECT: Playground Design Public Input Session
Poppleton Park Playground

INTRODUCTION:

As the Department of Public Services (DPS) continues implementing city-wide playground improvements, a priority of the available Parks and Recreation Bond, Poppleton Park is next on the list for playground improvements. Funding is budgeted this fiscal year in order to accomplish a fully inclusive and accessible playground at Poppleton Park.

Inclusive play is a top priority of the recently updated 2024-2028 Parks and Recreation Master Plan, and includes a recommended prioritization of inclusive playground installation based on a synthesis of information gathered or generated during the planning process. Poppleton is one of the highest ranking playgrounds for priority replacement with an inclusive playground.

BACKGROUND:

Poppleton park is a 17.2 acre community park. Although an entire park master plan was prepared in 2016, the area of focus for this project of playground improvements is in the existing area of the playground, along Oxford. The playground design architect from Penchura, the City's selected playground services consultant, will be in attendance at the August 5, 2025 Parks and Recreation Board meeting to review the draft concept and facilitate feedback.

The draft concept for the Poppleton playground has a very strong emphasis on inclusivity, utilizing elements for the wheelchair user, as well as a fully accessible main tower structure all the way to its highest point. Other features include accessible swings and seesaws. The concept also includes a solid safety surface for enhanced accessibility for all ages and abilities.

In order to ensure access to the playground, this project includes installation of sidewalks leading up to and around the playground from Oxford Street, a curb cut for nearby accessible parking, shade elements, more seating, and more trees are also part of this draft concept. Site amenities

such as a drinking fountain, bike racks, trash and recycling receptacles and an area for temporary restrooms have also been included. A restroom building is not part of this project, as the department is researching different styles and options to include in the park system, but can be added at a later time.

PUBLIC COMMUNICATIONS:

A robust notification program for the public input session and opportunity to provide comments was implemented in advance of the August 5, 2025 meeting. Postcards were sent to every resident, flyers were distributed throughout Birmingham neighborhoods, lawn signs were posted in the neighborhood of Poppleton Park and at other Community Parks such as Barnum, social media and e-newsletter promotions were utilized, there was an article in the August edition of the Around Town publication, and a press release was published.

A survey will be posted on Engage Birmingham, tentatively scheduled to be available between August 6-August 22, 2025 for the draft concept playground.

FISCAL IMPACT:

The budget for the fully inclusive play area including sidewalks and site amenities is \$1,100,000. Funding is available utilizing the Parks Land Improvements account, with the Parks and Recreation Bond Issue.

The Birmingham Rotary Club and the City are currently in the process of finalizing an agreement for a contribution of \$50,000 towards the Poppleton Park Playground Project in honor of their 100 year celebration last year.

SUMMARY:

The August 5, 2025 Parks and Recreation, in person or via zoom, will be a forum for the public to provide feedback and comments on the playground draft concept plan for Poppleton Park. For those that cannot make the meeting, opportunity for feedback is available via email or by participating in the survey on Engage Birmingham.

Upon completion of Board and public input, the architect will revise concepts as appropriate, and a final proposed design is planned to be presented at the September , 2025 Parks and Recreation Board meeting for approval and for recommendation to the City Commission for purchase.

ATTACHMENTS:

- Public notifications including the postcard, flyer, the August Around Town article, and press release
- Draft Concept plan and 3D renderings



Poppleton Park

Park Hours
6:00am to
10:00pm

Mystery Clue #4
Poppleton Park

Draw your favorite thing from the park on the back of the scavenger hunt checklist!

Playground
Tennis
Ball Diamond



To Report a Concern Contact :
Dept. of Public Services
248.530.1700
Police Dept. (Non-Emergency)



HELP *Design* PLAYGROUND IMPROVEMENTS AT POPPLETON PARK

HELP *Design* PLAYGROUND IMPROVEMENTS AT POPPLETON PARK

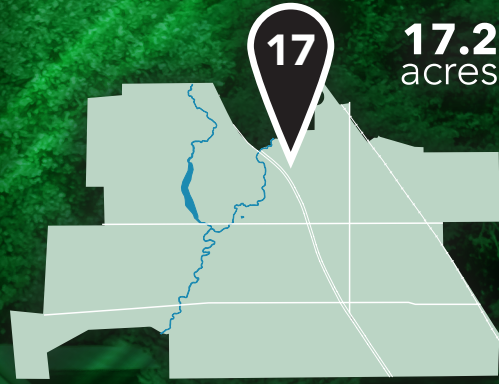

What

Poppleton Park Public Input Session

When

Parks and Recreation Board meeting
on Tuesday, August 5 at 6:30 p.m.

Where

851 S. Eton, Dept. of Public Services
conference room



Citywide playground improvements are underway, thanks to the voter approved 2020 Parks and Recreation Bond. Poppleton Park is slated for a fully inclusive, accessible playground.

Meet designers and share your feedback about design concepts at this public input session. **We want to hear from you!**



City of Birmingham
151 Martin Street
P.O. Box 3001
Birmingham, MI 48012-3001

PRSR STD
U.S. POSTAGE
PAID
BIRMINGHAM, MI
PERMIT NO. 180

ECRWSS
Postal Customer



Help design improvements to Poppleton Park

Impact Poppleton Park by sharing your ideas about new playground equipment.

What: Poppleton Park Public Input Session

Where: 851 S. Eton, Dept. of Public Services conference room

When: Parks & Rec Board meeting on Tues., Aug. 5 at 6:30 p.m.

Chat with designers and city staff about design options and your priorities. We want to hear from you!



For additional information please contact Connie Folk, Ice Arena and Facilities Superintendent at cfolk@bhamgov.org or scan the QR code.



PARKS & RECREATION NEWS

SHARE IDEAS FOR NEW POPPLETON PARK PLAYGROUND ON AUG. 5

HELP
Design
PLAYGROUND IMPROVEMENTS
AT POPPLETON PARK

What
Poppleton Park Public Input Session

When
Parks and Recreation Board meeting
on Tuesday, August 5 at 6:30 p.m.

Where
851 S. Eton, Dept. of Public Services
conference room

Citywide playground improvements are underway, thanks to the voter approved 2020 Parks and Recreation Bond. Poppleton Park is slated for a fully inclusive, accessible playground. Meet designers and share your feedback about design concepts at this public input session. **We want to hear from you!**

The Birmingham community is invited to share thoughts and ideas about design concepts for new, fully inclusive playground equipment slated for [Poppleton Park](#) during a public input session at the [Parks and Recreation Board](#) meeting on Tuesday, Aug. 5 at 6:30 p.m. The meeting will be held in the Department of Public Services conference room at 851 South Eton. Attendees may park inside the gate and use the side entrance.

Playground improvements are underway throughout Birmingham, thanks to the Parks and Recreation Bond approved by 70% of voters in 2020. Poppleton Park is up next for a new playscape,

following W. Lincoln Well Park and Pumphouse Park. The draft concept for Poppleton's playground, developed by the city's playground designer, Penchura, emphasizes inclusivity, utilizing elements for the wheelchair user, and a main tower structure that is fully accessible all the way to its highest point.

Other features include accessible swings and seesaws, and a solid safety surface underfoot for enhanced accessibility for all ages and abilities. Shade elements, more seating and more trees are also part of this concept. A potential restroom facility location is identified in the plan, with the type, style and installation to be determined at a later date.

"Inclusive playgrounds are called for in the latest Parks and Recreation Master Plan, and we are pleased to move forward with plans for a fully inclusive, accessible playground at Poppleton. We encourage the community to join us and share valuable feedback about draft concepts and ideas for the new play equipment," said Parks and Recreation Manager Carrie Laird. "The public's input will help us create a playscape children of all ages and abilities will love for many years to come."

Poppleton Park occupies over 17 acres on the east side of Woodward Avenue between Wimbleton Drive and Madison Street. Following playground improvements at Poppleton, next up will be Pembroke Park, Crestview, Kenning, Howarth, St. James and Linden Parks. Feedback for upcoming park improvement projects will also be solicited through projects on the city's public engagement platform, [Engage Birmingham](#).

See the the Poppleton Park concept plans and learn more at bhamgov.org/poppleton. Sign up for parks and recreation projects email list to receive notifications from the city at bhamgov.org/enews.



Carrie Laird <claird@bhamgov.org>

PRESS RELEASE: Community invited to share thoughts on inclusive Poppleton Park play equipment

Marianne Gamboa <MGamboa@bhamgov.org>
Bcc: Claird@bhamgov.org

Tue, Jul 22, 2025 at 3:02 PM



For Immediate Release

Contact:
Marianne Gamboa
(248) 530-1812

Community invited to share thoughts on inclusive Poppleton Park play equipment

BIRMINGHAM, Mich. July 22, 2025 – The Birmingham community is invited to share thoughts and ideas about design concepts for new, fully inclusive playground equipment slated for Poppleton Park during a public input session at the Parks and Recreation Board meeting on Tuesday, August 5 at 6:30 p.m. The meeting will be held in the Department of Public Services conference room at 851 South Eton. Attendees may park inside the gate and use the side entrance.

Citywide playground improvements are underway throughout Birmingham, thanks to the Parks and Recreation Bond approved by 70% of voters in 2020. Poppleton Park is up next for a new playground, following W. Lincoln Well Park and Pumphouse Park. The draft concept for the Poppleton playground, developed by the City's playground designer, Penchura, has a strong emphasis on inclusivity, utilizing elements for the wheelchair user, as well as a fully accessible main tower structure all the way to its highest point. Other features include accessible swings and seesaws. The concept calls for a solid safety surface for enhanced accessibility for all ages and abilities. Shade elements, more seating, and more trees are also part of this concept. A potential restroom facility location is identified in the plan, with the type, style and installation to be determined at a later date.

"Inclusive playgrounds are called for in the latest Parks and Recreation Master Plan, and we are pleased to move forward with plans for a fully inclusive, accessible playground at Poppleton. We encourage the community to join us and share valuable feedback about draft concepts and ideas for the new play equipment," said Parks and Recreation Manager Carrie Laird. "The public's input will help us create a playscape children of all ages and abilities will love for many years to come."

Poppleton Park is just over 17 acres and located on the east side of Woodward Avenue between Wimbleton Drive and Madison Street. Following playground improvements at Poppleton, next up will be Pembroke Park, Crestview, Kenning, Howarth, St. James and Linden Parks. Feedback for upcoming park improvement projects will also be solicited through projects on the City's public engagement platform, Engage Birmingham, at engage.bhamgov.org.

For more information and to view the Poppleton Park concept plans, visit bhamgov.org/poppleton and sign up to receive notifications from the City at bhamgov.org/enews.

About Birmingham

Birmingham, Mich. is a walkable community of more than 21,000 residents in southeast Oakland County, approximately 20 miles north of downtown Detroit. It has a vibrant retail and restaurant district in a historic downtown dating back to the 1830s, charming neighborhoods, more than 230 acres of parks, two nine-hole golf courses, an ice sports arena and highly rated schools. Learn more at bhamgov.org.

###







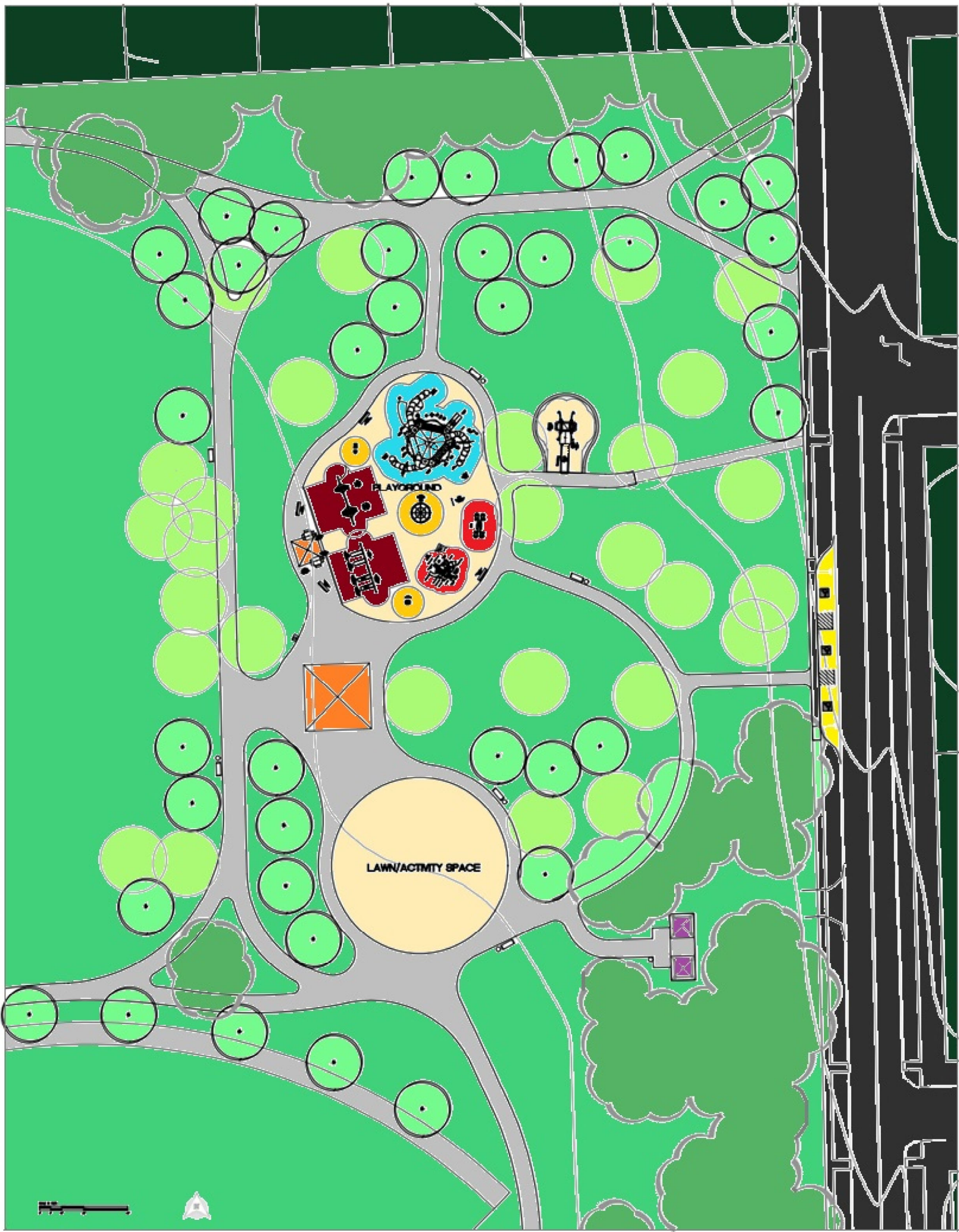

Sign up to receive newsletters and alerts from the City of Birmingham at bhamgov.org/enews.



_DSF0890.jpg
2644K



LEGEND



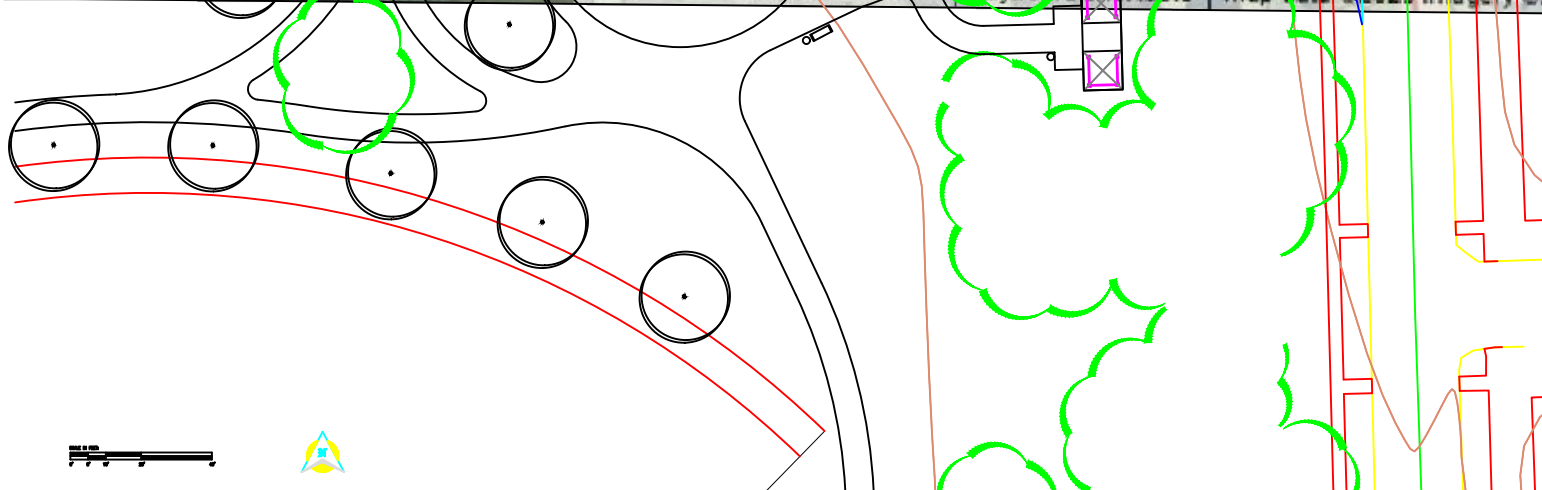
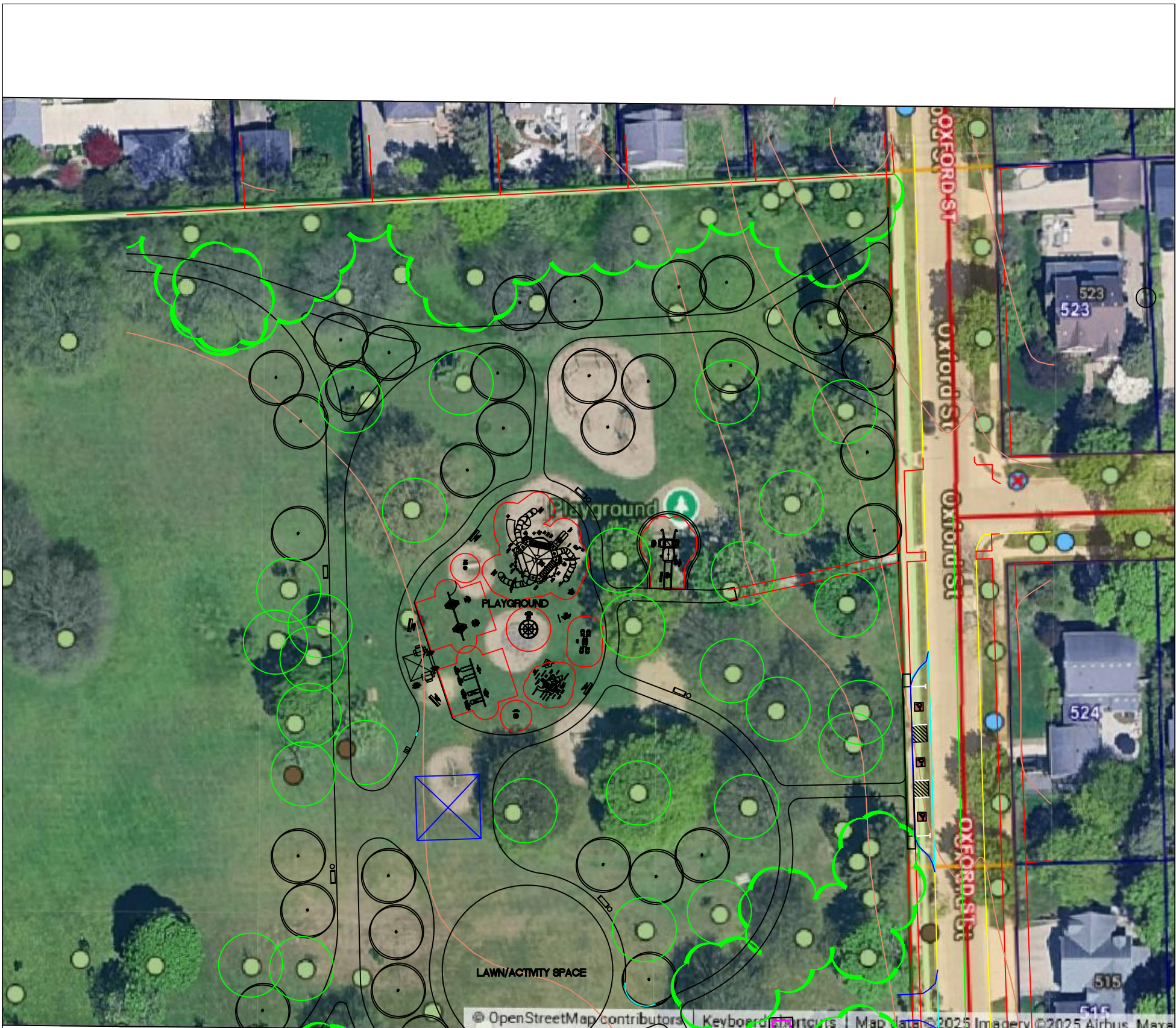

-  EXISTING TREES
-  PROPOSED DECIDUOUS TREE
-  PROPOSED SHADE STRUCTURE
-  PROPOSED RESTROOM ENCLOSURE
-  PROPOSED PARK BENCH
-  PROPOSED PLAYGROUND BENCH
-  PROPOSED FOUNTAIN
-  PROPOSED RECEPTACLE

PLAYGROUND CONCEPT PLAN

PL-1

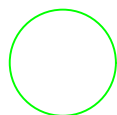
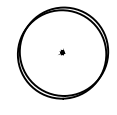
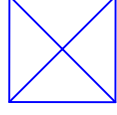
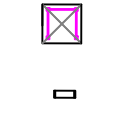

LEGEND

-  EXISTING TREES
-  PROPOSED DECIDUOUS TREE
-  PROPOSED SHADE STRUCTURE
-  PROPOSED RESTROOM ENCLOSURE
-  PROPOSED PARK BENCH
-  PROPOSED PLAYGROUND BENCH
-  PROPOSED FOUNTAIN
-  PROPOSED RECEPTACLE

PLAYGROUND CONCEPT PLAN

PL-1



Poppleton Park 900K Example

PEN1194652-01 • 3.12.2025





Poppleton Park 900K Example

PEN1194652-01 • 3.12.2025



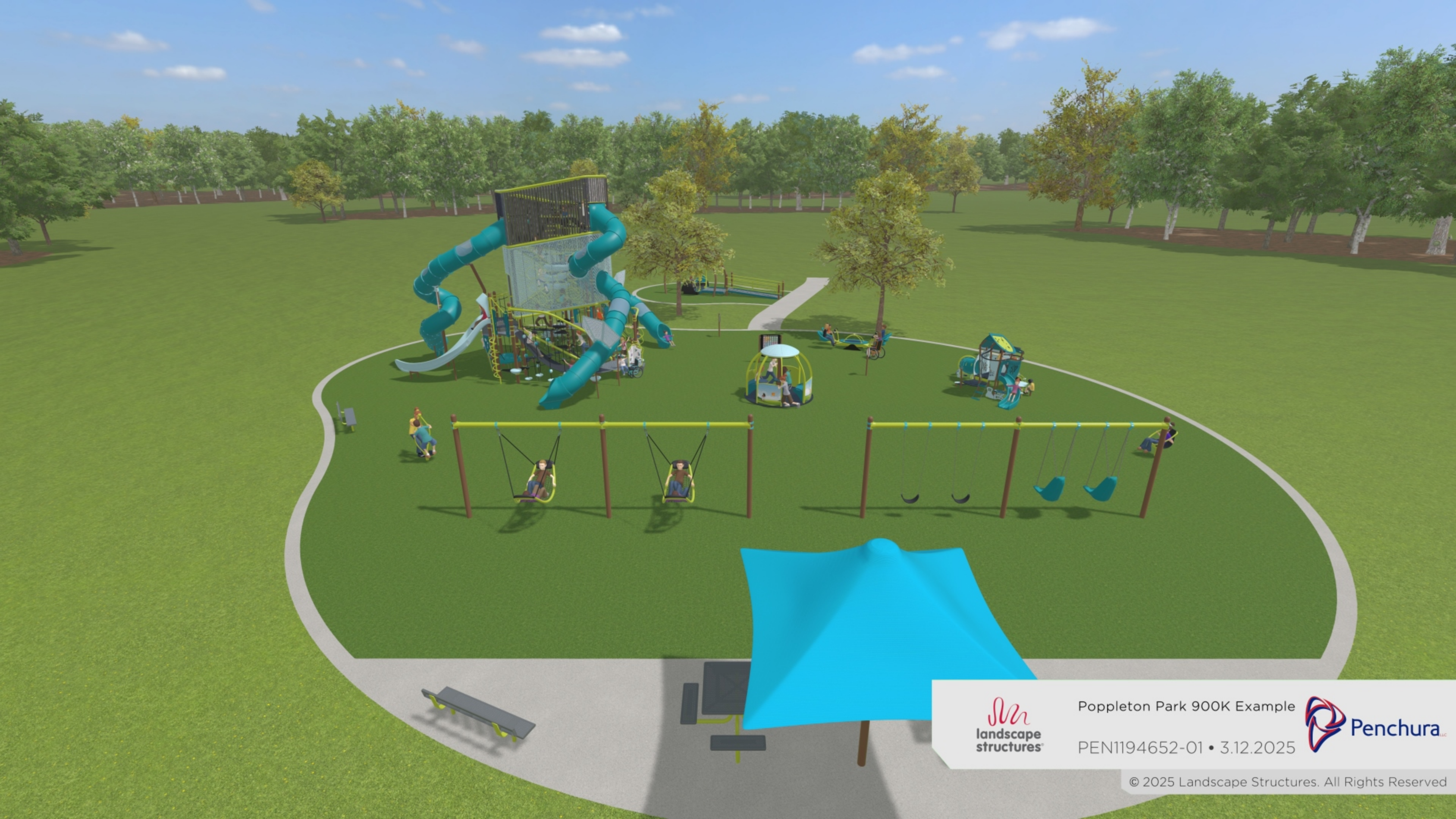

Poppleton Park 900K Example

PEN1194652-01 • 3.12.2025





Poppleton Park 900K Example

PEN1194652-01 • 3.12.2025





Poppleton Park 900K Example

PEN1194652-01 • 3.12.2025





Poppleton Park 900K Example

PEN1194652-01 • 3.12.2025





Poppleton Park 900K Example

PEN1194652-01 • 3.12.2025





Poppleton Park 900K Example

PEN1194652-01 • 3.12.2025





Poppleton Park 900K Example

PEN1194652-01 • 3.12.2025





Slr
landscape structures
playcity.com

Welcome

A WARNING

This play structure has been designed for children 5 to 12 years old and requires users to have sufficient strength and coordination. Adult supervision is strongly recommended.



Poppleton Park 900K Example

PEN1194652-01 • 3.12.2025



Poppleton Park Improvements

1 message

mattshalhoub@gmail.com <mattshalhoub@gmail.com>
To: cfolk@bhamgov.org

Mon, Jul 21, 2025 at 5:47 PM

Connie, my wife Shealyn and I moved to the Poppleton area last year (980 Wimbleton Dr). We have 3 and 4 year old boys. We use Poppleton Park frequently and love it. There's tons of young kids in the neighborhood now and I don't know how extensive of improvements are being considered, but some type of splash pad (big or small) would be amazing. We moved from Toronto where many parks have even tiny splash pad type features and they're utilized a ton in the summer months. To my knowledge there is no park in Birmingham with something like it and Poppleton park could be a great place to start! More than happy to discuss further if you'd like.

Matt Shalhoub

Poppleton Park Improvements

1 message

Christina O'Grady <cyeags1@me.com>

Tue, Jul 22, 2025 at 8:02 PM

To: cfolk@bhamgov.org

Hello, my name is Christina O'Grady and I live on Oakland in the Poppleton neighborhood. I am emailing as I likely will not be able to make it to the public input session regarding the park improvements, but do have some input. I would love to see an all inclusive park for kids with all abilities. A good example would be the playground at Kensington Metropark. We lived in Los Angeles before moving here, and they were everywhere. I haven't seen any others around like it, and I believe it would be nice as many children in the area aren't able to access most playground equipment. Please take my input into consideration when building the new playground.

Thank you for your time,

Christina O'Grady

562-213-6688



Pictures received as a Communication for Poppleton Park

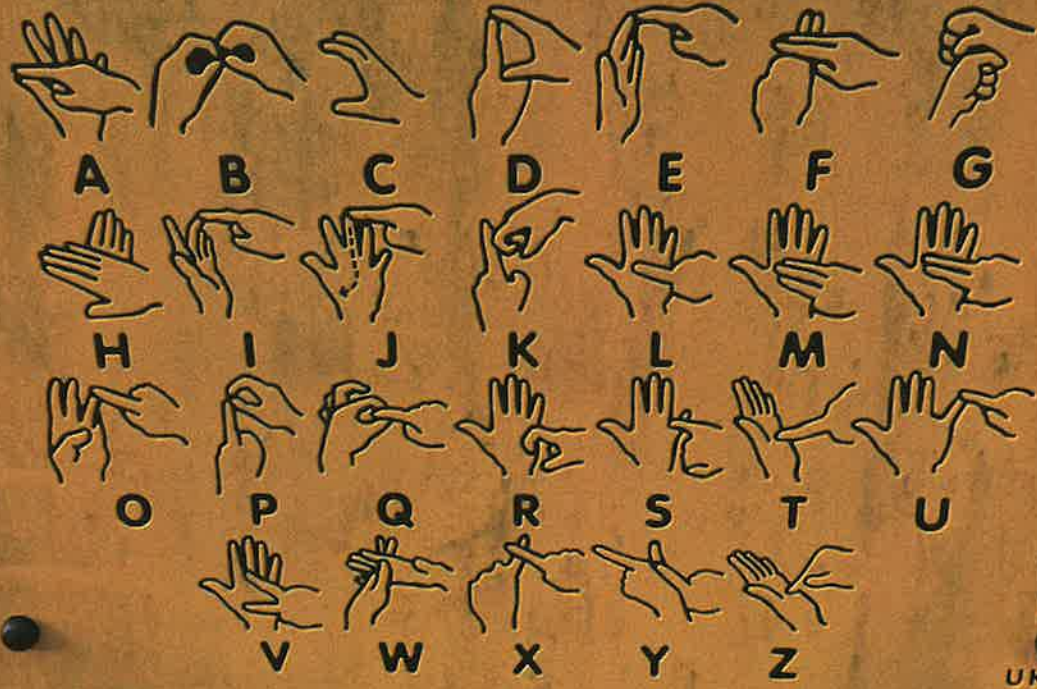

UK

Fwd: Park Improvement Ideas

1 message

Carrie Laird <Claird@bhamgov.org>
To: "Folk, Connie" <Cfolk@bhamgov.org>
Cc: Brad McNab <bmcnab@bhamgov.org>, Scott Zielinski <szielinski@bhamgov.org>

Mon, Jul 28, 2025 at 2:39 PM

Comments re: Poppleton Park. Please include in the August agenda packet. Thanks,

----- Forwarded message -----

From: **Mark K Pisani** <mark.pisani@basf.com>
Date: Mon, Jul 28, 2025 at 1:20 PM
Subject: Park Improvement Ideas
To: claird@bhamgov.org <claird@bhamgov.org>

Hi Carrie,

I hope this email finds you well. My neighbor Pam shared your email address with me after she kindly requested public input from North Poppleton residents on the park improvement project in our neighborhood Facebook group. I appreciate the opportunity to share my thoughts, and I'll do my best to attend the meeting if needed. With three kids, including an 8-month-old, breaking away after work can be quite challenging!

Here are two ideas that I believe could add value to our park:

Firstly, I think it would be beneficial to provide a fenced area for dogs or fence in the area where kids are playing. Unfortunately, some dog owners leave their pets unleashed, which can lead to scary situations. My oldest daughter was charged at by an unleashed dog when she was nearly three years old. Thankfully, I intervened in time, but the incident left her even at the age of 7 with a lasting fear of dogs. Just a couple of weeks ago, my daughter's flag football team had a similar experience with two smaller unleashed dogs running towards the playing area. While these dogs were friendly, it could have easily been a dangerous situation. I spoke to the owner, who assured me it wouldn't happen again, but it's always better to be safe than sorry. Please understand that I do love dogs, having grown up in a rural area surrounded by them, but safety is paramount.

Additionally, with the growing popularity of girls' sports, there is an increased demand for scrimmages and practices. I was wondering if it would be possible to create a youth-sized soccer and football field without field goals. While Adams Park has this feature, it unfortunately lacks shade. Perhaps we could take advantage of the tree lines in our park to lay out a field that would be shaded in the afternoon. This would make it much more comfortable for the kids to play.

Thank you for considering my suggestions. I look forward to seeing the improvements in our community park and am happy to provide any further input if needed.

Thank you!
Mark K. Pisani, P.E.
Electrical Engineer, GEC/DE, Technical Expertise Group

Mobile: +1 313 296-8758, Email: mark.pisani@basf.com
Postal Address: BASF Corporation, 1609 Biddle Avenue, 48192 Wyandotte, United States

[Survey Link](#)



Everyone takes electricity for granted – until the power is out!

--
Carrie A. Laird
Parks & Recreation Manager
[851 S. Eton](#)
[Birmingham, MI 48009](#)
248-530-1714

Important Note to Residents
Let's connect! Join the Citywide Email System to receive important City updates and critical information specific to your neighborhood at www.bhamgov.org/citywideemail.

Feedback for Poppleton Park

1 message

Kaitlyn Rich <kmalooly@gmail.com>
To: cfolk@bhamgov.org, Drew Rich <drich07@gmail.com>

Wed, Jul 30, 2025 at 11:56 AM

Hi Connie,

My name is Kaitlyn Rich. I live at 342 Henley St. which is one street over from Poppleton Park. I'm going to try to make the meeting next week, but I might have some conflicts with my children's activities that evening. I would like if the following thoughts, concerns and suggestions could be shared with the committee:

Preserving the Neighborhood Feel

As a parent and resident, I deeply value having a neighborhood park that feels safe and welcoming for our children. That said, one of my main concerns is maintaining the essence of this being a neighborhood park—not a destination spot for people driving in off Woodward Ave.

Safety for Children

The current visibility from Woodward invites a lot of outside traffic, which is concerning when we're trying to give our kids some freedom to play and be independent. We worry about high volumes of strangers consistently coming into the space.

Another major concern is the increase in car traffic the playground currently attracts—and how that could get even worse with a revamp that draws more visitors from outside the neighborhood.

Some of the streets leading to the park are already heavily used as cut-throughs, and this could intensify the problem, making it less safe for kids and families who live here.

I'd like to feel comfortable letting my kids walk or bike to the park on their own, but with rising traffic and non-local drivers cutting through, it doesn't feel as safe or neighborhood-friendly as it should.

Environmental Buffering: Privacy + Sound Barrier

One idea I'd like to propose is strategically planting trees or shrubs along the edge of the park that faces Woodward.

This would accomplish a few things: it would create a visual buffer that discourages people from pulling in off Woodward just because they see a playground, and it would help with the serious noise pollution from traffic, speeding, and unfortunately, drag racing that plagues our neighborhood.

Natural sound barriers like trees could help restore the peaceful, neighborhood feel we're all looking for.

This doesn't mean we're closing the park off to others—but it helps reinforce the idea that this is a space primarily for the neighborhood.

Design elements

Safety surfacing like poured-in-place rubber is ideal—especially for preventing injuries from falls. It's a small detail that makes a huge difference for kids of all ages.

Distinct areas designed for specific age groups. That way, younger children can play safely without being overwhelmed, and older kids still have equipment that challenges and engages them.

Integrating trees, plants, rocks, and even small water features can help children connect with nature.

Shaded areas are essential—not just for heat protection but for creating a calming, relaxed atmosphere where families can gather and stay longer.

A walking path would be a great addition, especially for parents, grandparents, or anyone wanting to get some light exercise while their kids play. I'd suggest exploring a path around the perimeter—so we can keep the big open field intact. My boys and many others use that space for football, baseball, and just being kids.

Adding a basketball court would be another way to give older kids a safe, positive place to gather and be active.

Sent from my iPhone

Poppleton Park

1 message

Jeff Weber <jweber@weberolcese.com>
To: Connie Folk <cfolk@bhamgov.org>

Thu, Jul 31, 2025 at 10:20 AM

Hi Connie,

I see there is a meeting regarding playground equipment at Poppleton next week. Has there ever been any talk about turning it into a true softball field with an infield and fence more suited for youth softball? Or even adding a second diamond with all the property they have? Trying to figure out if it's worth our time to appear at the meeting.

Thank you!

Regards,



Jeffrey M. Weber | Partner

weberolcese
Attorneys & Counselors

[2653 Industrial Row Drive | Troy, Michigan 48084](#)

D 248.458.0480 | C 248.321.0400 | F 248.484.6442

[Email](#) | [Website](#)



FOR IMMEDIATE RELEASE

Contact: Marianne Gamboa
Communications Director
(248) 530-1812
mgamboa@bhamgov.org

Volunteers sought to help plant native perennials in Booth Park on Aug. 6

BIRMINGHAM, Mich. July 29, 2025 – The City of Birmingham Department of Public Services (DPS) is seeking volunteers to plant native perennial seedlings in Booth Park on Wednesday, Aug. 6 from 10 a.m. to 12 p.m., part of a project to reclaim the park’s natural areas from invasive plant species.

People of all ages are invited to join staff from both DPS and the Oakland County Cooperative Invasive Species Management Area (OC CISMA) to install young native perennials, such as purple coneflower, during the native perennial public planting event. These plants will help prevent the regrowth of invasive non-native species in the natural area between the Rouge River and the limestone gravel walking path on the east side of Booth Park.

Interested participants should register online at bhamgov.org/donate. Work gloves and hand shovels will be provided for registered volunteers.

Last year, Birmingham was awarded a Community Habitat Improvement Project (CHIPs) grant through the OC CISMA to help fund the Booth Park natural area revitalization project to combat the spread of aggressive invasive woody species, such as buckthorn and honeysuckle. If left unchecked, these plants can quickly overtake natural areas and prevent native species from proper establishment and survival. DPS crews have worked hard to remove invasive woody species and invasive perennials from the area and reestablish the riparian area with three types of native seed mixes and live staked trees. The native perennials installed during the Aug. 6 public planting will help protect the area from a recurrence of invasive species while the wildflower seed germinates and becomes established, which can sometimes take up to three years.

“Please come help the city restore natural beauty and provide local fauna and animals with the resources they need to succeed, all while making our section of the Rouge River Corridor better for our native species to thrive even more,” says Brendan McGaughey, DPS forestry and environment foreman.

Booth Park is located at the southwest corner of North Old Woodward and Harmon. Please contact the city’s recreation office at (248) 530-1640 with questions about the public planting event.

About Birmingham

Birmingham, Mich. is a walkable community of more than 21,000 residents in southeast Oakland County, approximately 20 miles north of downtown Detroit. It has a vibrant retail and restaurant district in a historic downtown dating back to the 1830s, charming neighborhoods, more than 230 acres of parks, two nine-hole golf courses, an ice sports arena and highly rated schools. Learn more at bhamgov.org.

###



MEMORANDUM

Department of Public Services

DATE: July 31, 2025

TO: Parks and Recreation Board

FROM: Carrie Laird, Parks and Recreation Manager

SUBJECT: Pumphouse Park and West Lincoln Well & Park Update

The recommended playground improvements for Pumphouse Park and West Lincoln Well & Park were approved by the City Commission at the June 23, 2025 meeting ([Agenda/Minutes](#)). The purchase order has been processed and equipment is ordered.

An excerpt from the minutes for the June 23, 2025 City Commission meeting are attached to this report. The Commission decided not to change the name of either park.

LLC

CE Coatta presented the item. Staff answered informational questions from the Commission.

Commissioners raised the following points during discussion:

- It would have been preferable if curbs could have been added to the project.
- Adding curbs would have significantly changed the cost to the City. The prior change in the cost split had not contemplated the addition of curbs. If curbs were added, all previous motions regarding this project would have to be rescinded and re-done.
- The scope of the project was redefined.

MOTION: Motion by Long, seconded by Haig:

To award the Wimbledon Phase 1 Project Contract #7-24 (P) to Eminent Excavating LLC in the amount of \$3,644,249.50 plus a 10% construction contingency for a total of \$4,008,674.45. In addition, to authorize the Mayor and Clerk to sign the agreement on behalf of the City contingent upon execution of the agreement and meeting all insurance and bond requirements by Eminent Excavating LLC. Funding for this project has been budgeted in the following accounts, which the fund number, fund ID, project award, 10% contingencies, and total amounts are set forth on page three of 8D of the packet, and to approve the appropriation and amendment of the budget as follows, the sewer fund, water fund, revenues and expenditures also set forth on pages three and four of 8D of the packet.

ROLL CALL VOTE

Ayes: Emerine, Haig, Schafer, Baller, Host, Longe, Long

Nays: None

06-219-25 Pumphouse Park & West Lincoln Well & Park Playgrounds

DPSD Zielinski presented the item. Staff answered informational questions from the Commission.

Commissioners raised the following points during discussion:

- Staff did a great job on the presentation, and in capturing the concerns of the residents.
- The Parks and Recreation Board deserved thanks for its hard work.
- The inclusion of options for children with different abilities was valuable.
- All sustainability-oriented improvements to the parks should have child-friendly educational signage with explanations.
- There was disagreement over whether the colors of the play structures should be more muted to align with expressed resident preferences, or whether children might enjoy brighter tones.
- Since the Commission encouraged and received resident feedback, it might be most appropriate to respect the feedback that was given. As a compromise, it might be possible to largely align with resident color preferences while increasing the amount of color a bit.
- Garbage cans and benches should be separated.
- The signage for the Parks should align with the Wayfinding standards.
- Retaining the names Pumphouse Park and West Lincoln Well and Park was positive. The City should consider installing signs in child-friendly language in each Park explaining pumphouses and wells, respectively.
- Alternatively, Pumphouse Park could be retained and West Lincoln Well and Park could be made a bit more child-friendly.
- Children may be inclined to climb the 'spires'. This aspect might merit reconsideration.
- Penchura designed Scarlet's Playground, a nearby, completely accessible park.
- If Penchura, the Parks and Recreation Board, and the public did not raise concerns about the 'spires', they might not necessitate further review.
- The categorical age division for playground equipment was useful.
- It would be helpful to learn more about poured-in-place surface costs, maintenance, and longevity at a later time.
- Adding more benches around the play structure could be of benefit. It might be possible to add benches in the future via the general Parks and Recreation budget, or as donor items.

MOTION: Motion by Schafer, seconded by Host:

To approve the playground layout design for Pumphouse Park and purchase of playground equipment through Landscape Structures, Inc. with Sourcewell cooperative purchase pricing in the amount of \$85,159.57, and the installation of the equipment by Penchura, LLC in the amount

of \$68,258.00 for a total purchase price of \$153,417.57. Funds are available in the Parks System Construction Fund, account #408.2-901.751-979.0000.

AND

To approve the playground layout design for West Lincoln Well & Park and purchase of playground equipment through Landscape Structures, Inc. with Sourcewell cooperative purchase pricing in the amount of \$118,552.53, and the installation of the equipment by Penchura, LLC in the amount of \$105,638.00 for a total purchase price of \$224,190.53. Funds are available in the Parks System Construction Fund, account #408.2-901.751-979.0000.

AND

To affirm maintaining the name Pumphouse Park and West Lincoln Well & Park.

ROLL CALL VOTE

Ayes: Emerine, Haig, Schafer, Baller, Host, Longe, Long

Nays: None

06-220-25 Cross Connection Control Program

DPSD Zielinski presented the item. Staff answered informational questions from the Commission.

Commissioners raised the following points during discussion:

- Challenges could arise in carrying out these inspections.

MOTION: Motion by Long, seconded by Host:

To approve two five-year agreements with HydroCorp for Commercial and Residential Cross Connection Control Programs in the amounts not to exceed \$96,600.11 for the Commercial Program, and \$643,897.84 for the Residential Program. In addition, to authorize the Mayor and City Clerk to sign the agreements on behalf of the City. Funding for both projects has been budgeted in account #591-537.007-811.0000.

Commission comment on the motion:

- Staff deserved thanks for the presentation. It was helpful to know that staff has a good working relationship with HydroCorp and a good understanding of the work required.
- Some members of the public may object to a State government department requesting entry into their home to conduct inspections.
- The requirement is that the City has to attempt the inspections. It is not a requirement that residents must permit the inspections.
- Clear and adequate communication to residents about the program's inspection requests will be essential.

Public Comment

Jenny Johanns of HydroCorp commented that these inspections arise from the Michigan Safe Drinking Water Act, and that the requirements around these inspections are enforceable by EGLE.

ROLL CALL VOTE

Ayes: Emerine, Haig, Schafer, Baller, Host, Longe, Long

Nays: None

Commission Items for Future Discussion

Commissioner Host made a motion to look at the residential building ordinances. It was noted that those ordinances would be reviewed as part of the ordinance update process. Motion died for lack of a second.

06-221-25 Planning Board Review of Outdoor Dining Permissions

MPT Baller presented the proposed item.

MOTION: Motion by Baller, seconded by Host:

To ask the Planning Board to take a look at the ordinance regarding the use of public property for outdoor dining, and whether it is proper to seek approval from property owners for the use